

IMPORTANT!
DO NOT DESTROY

¡IMPORTANTE!
NO DESTRUIR



Installation and Maintenance Manual

with **Safety Information**
and Parts List

RECOMMENDED SPARE PARTS HIGHLIGHTED IN GRAY

Manual de Instalación y Mantenimiento

con **Información sobre Seguridad**
y Lista de Partes

PARTES DE REPUESTO RECOMENDADAS SE RESALTAN EN GRIS

**Model 138-ACC, LRC
LRS, & LRSS**

Effective February 2007
(Supersedes February 2004)

Bulletin # 583



138-ACC

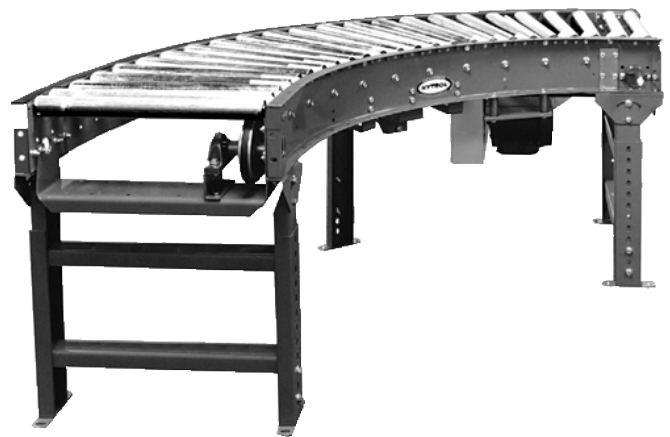

138-LRC

HYTROL CONVEYOR CO., INC.

Jonesboro, Arkansas

● Table of Contents

Warning Signs	3
INTRODUCTION	
Receiving and Uncrating	4
INSTALLATION	
Installation Safety Precautions	4
Support Installation	5
Ceiling Hanger Installation	6
Conveyor Set-Up	7
Connecting the V-Belts	8
Racked Sections	10
Slave Driven Curve or Spur	11
Pressure Adjustment	12
Electrical Equipment	14
OPERATION	
Operation Safety Precautions	16
Conveyor Start-Up	16
MAINTENANCE	
Maintenance Safety Precautions	17
Lubrication	17
Belt Replacement	18
Belt Tension Adjustment	20
Drive Chain Alignment and Tension	21
Trouble Shooting	22
Maintenance Checklist	24
REPLACEMENT PARTS	
How To Order Replacement Parts	25
138-ACC Parts Drawing & List	26
LRC-90° Parts Drawing & List	28
LRC-60° Parts Drawing & List	30
LRC-45° Parts Drawing & List	32
LRC-30° Parts Drawing & List	34
LRS-45° Parts Drawing & List	36
LRS-30° Parts Drawing & List	38
LRSS-45° Parts Drawing & List	40
LRSS-30° Parts Drawing & List	42
138-ACC Sheave Retainers	44
LRC,LRS, & LRSS Sheave Retainers	45
Slave Connection Parts Drawing	46

● Tabla de Contenido

Señales de Advertencia	3
INTRODUCCION	
Recepción y Desembalaje	4
INSTALACION	
Medidas de Seguridad al Instalar	4
Instalación de los Soportes	5
Instalación de los Soportes de Techo	6
Montaje	7
Conectando las Bandas-V	8
Secciones Descuadradas	10
Curva o Espuela Motriz Esclavada	11
Ajuste de Presión	12
Equipo Eléctrico	14
OPERACION	
Seguridad en la Operación	16
Arranque del Transportador	16
MAINTENIMIENTO	
Seguridad en el Mantenimiento	17
Lubricación	17
Reemplazo de la Banda	18
Tensión de la Banda	20
Alineación y Tensión de la Cadena	21
Resolviendo Problemas	22
Lista de Mantenimiento Preventivo	24
PARTES DE REPUESTO	
Como Ordenar Repuestos	25
138-ACC Dibujo & Lista de Partes	26
LRC-90° Dibujo & Lista de Partes	28
LRC-60° Dibujo & Lista de Partes	30
LRC-45° Dibujo & Lista de Partes	32
LRC-30° Dibujo & Lista de Partes	34
LRS-45° Dibujo & Lista de Partes	36
LRS-30° Dibujo & Lista de Partes	38
LRSS-45° Dibujo & Lista de Partes	40
LRSS-30° Dibujo & Lista de Partes	42
Retenedores de Polea 138-ACC	44
Retenedores LRC,LRS, & LRSS	45
Conexión Esclavada	46

● Warning Signs

In an effort to reduce the possibility of injury to personnel working around HYTROL conveying equipment, warning signs are placed at various points on the equipment to alert them of potential dangers. Please check equipment and note all warning signs. Make certain your personnel are alerted to and obey these warnings. Shown below are typical signs that are attached to this equipment.

WARNING!

DO NOT START CONVEYOR UNTIL PERSONNEL ARE CLEAR

PLACED ON ALL POWERED CONVEYORS NEAR DRIVE AND/OR CONTROLS.

ADVERTENCIA!

NO PONER EN MARCHA EL TRANSPORTADOR HASTA QUE TODO EL PERSONAL ESTE ALEJADO

COLOCADAS EN TODOS LOS TRANSPORTADORES MOTORIZADOS CERCA AL MOTOR Y/O LOS CONTROLES

● Señales de Advertencia

En un esfuerzo por reducir la posibilidad de accidentes al personal trabajando junto al equipo de transportación HYTROL, se colocan señales de advertencia en diferentes puntos del equipo para alertarlos de riesgos potenciales. Por favor verifique el equipo y asegúrese de ver todas las señales de advertencia. Asegúrese de que su personal esté alerta y obedezca las señales. Abajo se muestran señales típicas que se encuentran en este equipo.

WARNING

Servicing moving or energized equipment can cause severe injury

LOCK OUT POWER before removing guard



ADVERTENCIA!

El mantenimiento de partes eléctricas o en movimiento puede causar lesiones graves.

DESCONECTAR la energía antes de remover la guarda.

PLACED NEXT TO DRIVE, BOTH SIDES.

COLOCADAS JUNTO A LA UNIDAD MOTRIZ, EN AMBOS LADOS.

DANGER

Climbing, sitting, walking or riding on conveyor at any time will cause severe injury or death
KEEP OFF



PELIGRO!

Subirse, sentarse, caminar o viajar en el transportador en cualquier momento, puede causar lesiones graves o incluso la muerte.
CONSERVE DISTANCIA

PLACED ON 20 FT. INTERVALS, BOTH SIDES.

COLOCADAS EN INTERVALOS DE 20 PIES, A AMBOS LADOS.

WARNING

Exposed moving parts can cause severe injury
LOCK OUT POWER before removing guard



ADVERTENCIA!

Partes expuestas en movimiento pueden causar lesiones graves.
DESCONECTAR la energía antes de remover la guarda.

PLACED ON ALL CHAIN GUARDS.

COLOCADAS EN TODAS LAS GUARDA CADENAS.

WARNING

Moving equipment can cause severe injury

KEEP AWAY



ADVERTENCIA!

Partes en movimiento pueden causar lesiones graves.

NO SE ACERQUE

PLACED ON TERMINATING ENDS.

COLOCADAS EN LOS EXTREMOS.

WARNING

NEVER... START CONVEYOR UNTIL PERSONNEL ARE CLEAR
NEVER... LUBRICATE OR REPAIR WHILE CONVEYOR IS RUNNING
NEVER... RUN THE CONVEYOR WITH GUARDS REMOVED
NEVER... PUT YOUR HANDS ON THE CONVEYOR OR IN THE CONVEYOR WHEN IT IS RUNNING.
NEVER... ALLOW ANY PART OF YOUR BODY TO COME IN CONTACT WITH THE CONVEYOR PULLEYS WHILE IT IS RUNNING.
IT IS THE EMPLOYERS RESPONSIBILITY TO IMPLEMENT THE ABOVE AND ALSO TO PROVIDE ADEQUATE PROTECTION FOR ANY PARTICULAR USE, OPERATION OR SERVICE.
DO NOT REMOVE THIS SIGN FROM THIS MACHINE

PLACED AT DRIVE OF ALL POWERED CONVEYORS.

ADVERTENCIA

NUNCA... ARRANCAR EL TRANSPORTADOR HASTA QUE TODO EL PERSONAL ESTE ALEJADO
NUNCA... LUBRICAR O REPARAR MIENTRAS EL TRANSPORTADOR ESTE EN FUNCIONAMIENTO
NUNCA... HACER FUNCIONAR EL TRANSPORTADOR CON LAS GUARDAS REMOVIDAS
NUNCA... COLOCAR LAS MANOS SOBRE O DENTRO DEL TRANSPORTADOR CUANDO ESTE EN FUNCIONAMIENTO
NUNCA... PERMITIR QUE ALGUNA PARTE DEL CUERPO ESTE EN CONTACTO CON LAS POLEAS DEL TRANSPORTADOR MIENTRAS ESTE EN FUNCIONAMIENTO
ES RESPONSABILIDAD DE LOS SUPERVISORES IMPLEMENTAR LAS SEÑALES ANTERIORES Y TAMBIEN PROVEER LA ADECUADA PROTECCION PARA CUALQUIER USO, OPERACION O SERVICIO PARTICULAR.
NO REMUEVA ESTA SEÑAL DE LA MAQUINA

COLOCADAS EN LA UNIDAD MOTRIZ DE TODOS LOS TRANS - PORTADORES MOTORIZADOS.

INTRODUCTION

This manual provides guidelines and procedures for installing, operating, and maintaining your conveyor. A complete parts list is provided with recommended spare parts highlighted in gray. Important safety information is also provided throughout the manual. For safety to personnel and for proper operation of your conveyor, it is recommended that you read and follow the instructions provided in this manual.

Este manual provee las pautas y los procedimientos para instalar, operar, y mantener su transportador. Se proporciona una lista completa de repuestos, de los cuales, los recomendados, estarán resaltados en gris. También se proporciona información importante de seguridad a lo largo de este manual. Para seguridad del personal y para un funcionamiento apropiado del transportador, se recomienda que lea y siga las instrucciones proporcionadas en este manual.

● Receiving and Uncrating

1. . . Check the number of items received against the bill of lading.
2. . . Examine condition of equipment to determine if any damage occurred during shipment.
3. . . Move all crates to area of installation.
4. . . Remove crating and check for optional equipment that may be fastened to the conveyor. Make sure these parts (or any foreign pieces) are removed.

NOTE: If damage has occurred or freight is missing, see the “Important Notice” attached to the crate.

● Recepción y Desembalaje

1. . . Verifique el número de partes recibidas con el conocimiento del embarque.
2. . . Examine las condiciones del equipo para determinar si algún daño ha ocurrido durante la transportación.
3. . . Mueva todo el equipo hacia el área de instalación.
4. . . Remueva todos los empaques y verifique si hay partes opcionales que deben estar atadas al equipo. Asegúrese de que estas partes (o cualquier otras partes externas) sean removidas.

NOTA: Si algún daño ha ocurrido o falta cargamento, vea las “Notas Importantes” adheridas al embalaje.

INSTALLATION

● Installation Safety Precautions for Conveyors and Related Equipment

GUARDS AND GUARDING

Interfacing of Equipment. When two or more pieces of equipment are interfaced, special attention shall be given to the interfaced area to insure the presence of adequate guarding and safety devices.

Guarding Exceptions. Wherever conditions prevail that would require guarding under these standards, but such guarding would render the conveyor unusable, prominent warning means shall be provided in the area or on the equipment in lieu of guarding.

Guarded by Location or Position. Where necessary for the protection of employees from hazards, all exposed moving machinery parts that present a hazard to employees at their work station shall be mechanically or electrically guarded, or guarded by location or position.

When a conveyor passes over a walkway, roadway, or work station, it is considered guarded solely by location or position if all moving parts are at least 8 ft. (2.44 m) above the floor or walking surface or are otherwise located so that the employee cannot

INSTALACION

● Medidas de Seguridad al Instalar Transportadores y Equipos Relacionados

GUARDAS Y PROTECCIONES

Union del Equipo. Cuando dos o más piezas del equipo van unidas, debe ponerse especial atención al área de union para asegurar que las guardas adecuadas y los dispositivos de seguridad estén presentes.

Excepciones de Protección. Dondequiera que las guardas sean necesarias, pero que la colocación de las mismas inhabilite el uso del transportador, se proporcionarán señales de advertencia visibles en el área o en el equipo en vez de las guardas.

Protección dada por Posición o Ubicación. Cuando sea necesaria la protección de los empleados contra posibles riesgos, todas las partes del equipo que estén expuestas y en movimiento, y que puedan presentar un peligro para ellos en sus puestos de trabajo, serán protegidas mecánica o eléctricamente, o protegidas por su posición o ubicación.

Quando el transportador está instalado sobre pasillos, corredores o puestos de trabajo, se considera que está protegido únicamente por localización o posición si todas las partes en

inadvertently come in contact with hazardous moving parts. Although overhead conveyors may be guarded by location, spill guard, pan guards, or equivalent shall be provided if the product may fall off the conveyor for any reason and if personnel would be endangered.

HEADROOM

When conveyors are installed above exit passageways, aisles, or corridors, there shall be provided a minimum clearance of 6 ft. 8 in. (2.032 m) measured vertically from the floor or walking surface to the lowest part of the conveyor or guards.

Where system function will be impaired by providing the minimum clearance of 6 ft. 8 in. (2.032 m) through an emergency exit, alternate passageways shall be provided.

It is permissible to allow passage under conveyors with less than 6 ft. 8 in. (2.032 m) clearance from the floor for other than emergency exits if a suitable warning indicates low headroom.

movimiento están mínimo a 8 pies (2.44m) de altura del piso, o si está localizado de tal manera que el empleado no pueda entrar en contacto inadvertidamente con dichas partes.

A pesar de que los transportadores aéreos pueden estar protegidos por su localización, guardas laterales e inferiores deben ser proporcionadas para evitar que el producto se caiga del transportador y así mantener al personal fuera de peligro.

UBICACION SUPERIOR

Cuando los transportadores son instalados sobre pasillos o corredores de salida, debe dejarse un espacio libre de mínimo 6 pies 8 pulgadas (2,032m) de extensión, medido verticalmente desde el piso o área de tránsito hasta la parte más baja del transportador o de las guardas.

Si se proporcionan señales de advertencia adecuadas indicando baja altura; es posible dejar espacio libre con menos de 6 pies 8 pulgadas (2.032m) de extensión entre el piso y el transportador en los pasillos que no sean salidas de emergencia.

● Support Installation

1. . . Determine primary direction of product flow. Figure 5A indicates the preferred flow as related to the drive.
2. . . Refer to "Match-Mark" numbers on ends of conveyor sections. (Figure 5A).
3. . . Attach supports to both ends of drive section and to one end of intermediate or tail sections (Figure 5A). Hand tighten bolts only at this time.
4. . . Adjust elevation to required height.

● Instalación de los Soportes

1. . . Determine la dirección primaria del flujo del producto. La figura 5A indica el flujo preferido en relación con la unidad motriz.
2. . . Refiérase a las "Etiquetas de Secuencia de Armado" situadas al final de las secciones del transportador. (Figura 5A).
3. . . Fije los soportes en ambos extremos de la sección motriz y a un extremo de la sección intermedia o final (Figura 5A). Apriete los tornillos manualmente.
4. . . Ajuste la elevación a la altura requerida.

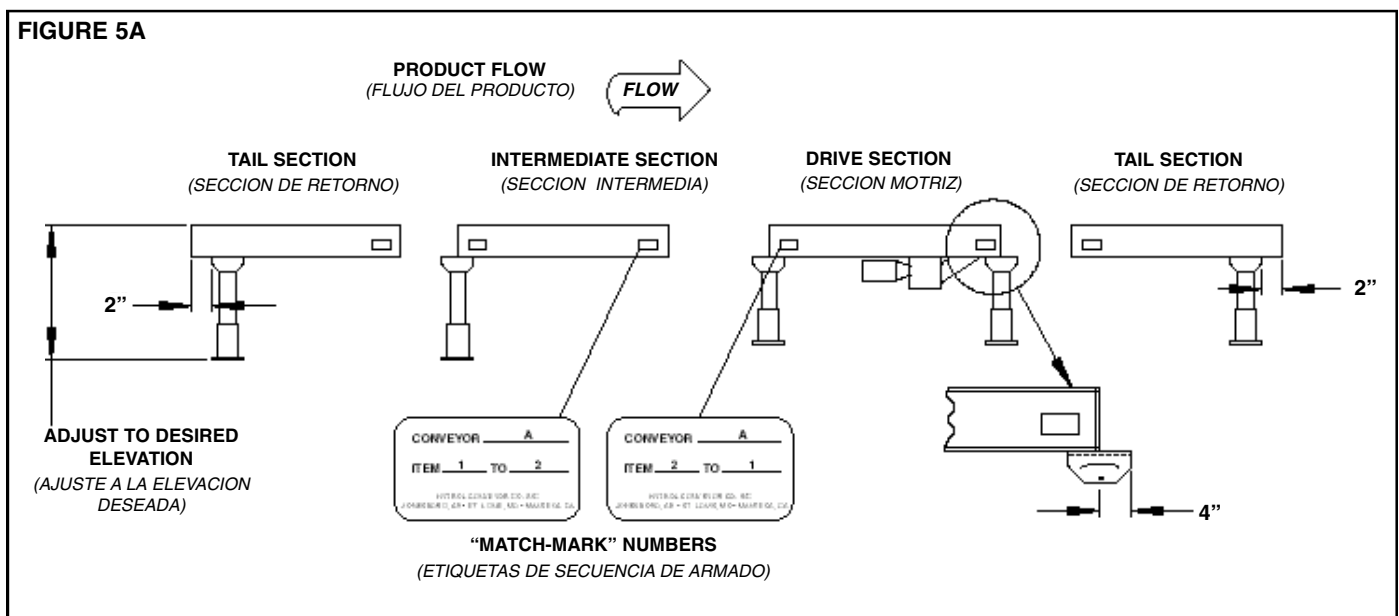

● Ceiling Hanger Installation

If conveyors are to be used in an overhead application, ceiling hangers may have been supplied in place of floor supports.

Figure 6A shows how a ceiling hanger mounts to a conveyor section. Ceiling hangers should be mounted at section joints. For safety information concerning conveyors mounted overhead, refer to “**Installation Safety Precautions**” on Page 4.

NOTE: When installing ceiling hanger rods in an existing building, all methods of attachment must comply with local building codes.

● Instalación de los Soportes de Techo

Si los transportadores van a ser usados en aplicaciones aéreas o superiores, soportes colgantes del techo pudieron haber sido suministrados en vez de los soportes de piso.

*La Figura 6A muestra como un soporte colgante de techo se instala en un transportador. Los soportes colgantes deben montarse en la unión de las secciones. Para información de seguridad respecto al montaje de transportadores aéreos, refiérase a “**Medidas de Seguridad al Instalar**” en la página 4.*

NOTA: Cuando se instalan varillas colgantes al techo en una construcción existente, todos los métodos de unión deben cumplir con los códigos locales de construcción.

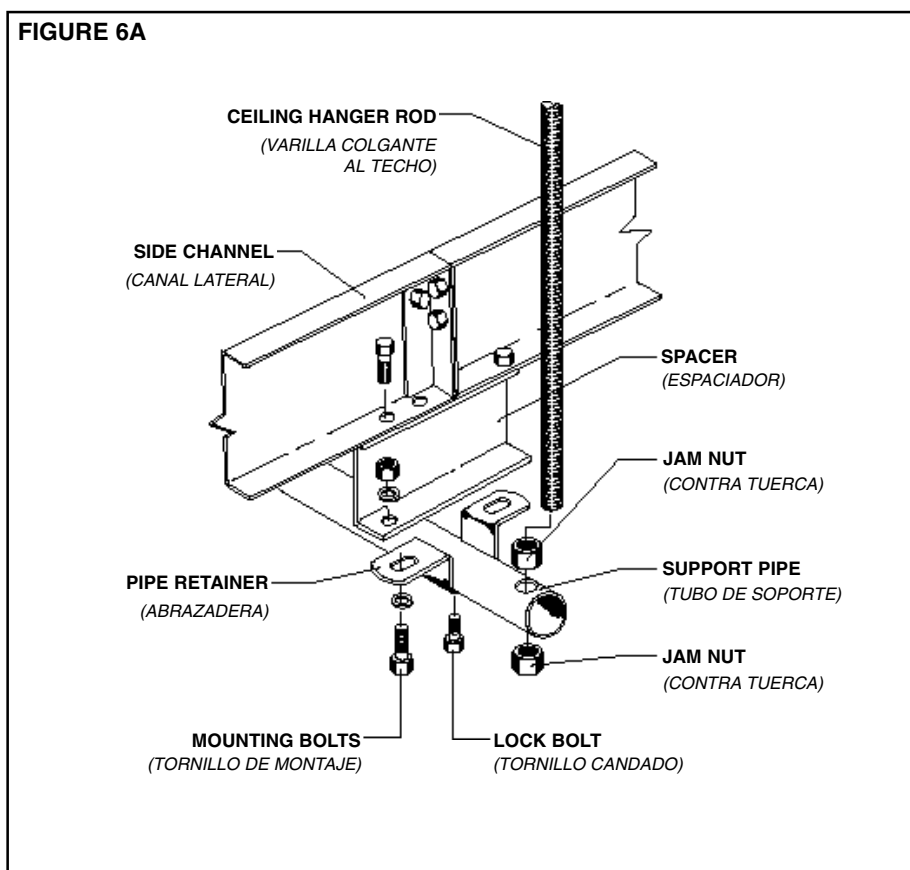

● Conveyor Set-Up

Re-check the “match-mark” numbers to see that adjoining sections are in proper sequence and follow these steps below to set up the conveyor.

1. . . Mark a chalk line on floor to locate center of the conveyor. (Floor Mounted Conveyors).
2. . . Place the drive section in position.
3. . . Install remaining sections placing end without support on extend pivot plate of previous section (Figure 7B).
4. . . Complete installation of Joint V-Belt Shield (item 54 in Parts List on Page 27): 1) Remove top bolt from butt coupling on v-belt side of adjoining section, 2) Join sections, and 3) Reinstall bolt through butt coupling, side channel, and v-belt shield.
5. . . Fasten sections together with butt couplings and pivot plates (Figure 7A). Hand tighten bolts only at this time.
6. . . Connect V-belts per instructions on Page 8.
7. . . Check to see that all “ACC” bed sections are square. Refer to Page 10 for Instructions on How To Square The Beds.
8. . . Spurs (LRS or LRSS) are attached to side of ACC with “K” brackets as shown in Figure 8A.
9. . . Curves (LRC) or spurs that have no drive may be slave driven from ACC. See Page 11 for instructions on connecting the drive chain.

● Montaje

Revise las Etiquetas de Secuencia de Armado para asegurarse que las secciones estén unidas en el orden correcto y tome los siguientes pasos para armar el transportador.

1. . . Marque con tiza una línea en el suelo para ubicar el centro del transportador.
2. . . Coloque la sección motriz en posición.
3. . . Instale las secciones restantes, colocando el extremo sin soporte en la placa pivote del soporte de la sección anterior (Figura 7B).
4. . . Complete la instalación de la unión de la guarda de la banda V (parte 54 en La Lista de Partes de la Página 27). Remueva el tornillo superior de la placa de unión del lado de la banda V de la sección adjunta. Unir las secciones, reinstalar el tornillo superior a través de la placa de unión, el canal lateral y la guarda de la banda V.
5. . . Sujete las secciones con placas de unión y placas pivote (Figura 7A). Apriete los tornillos manualmente.
6. . . Conecte las Bandas-V usando las instrucciones de la página 8.
7. . . Verifique que todas las secciones “ACC” de cama estén encuadradas. Vea la página 10 para instrucciones de como encuadrar las camas.
8. . . Espuelas (LRS o LRSS) están a un lado del ACC con un soporte “K” como se muestra en Figura 8A.
9. . . Curvas (LRC) o espuelas que no tienen unidad motriz pueden ser impulsadas por modelos ACC. Vea las instrucciones en la página 11 para conectar la cadena motriz.

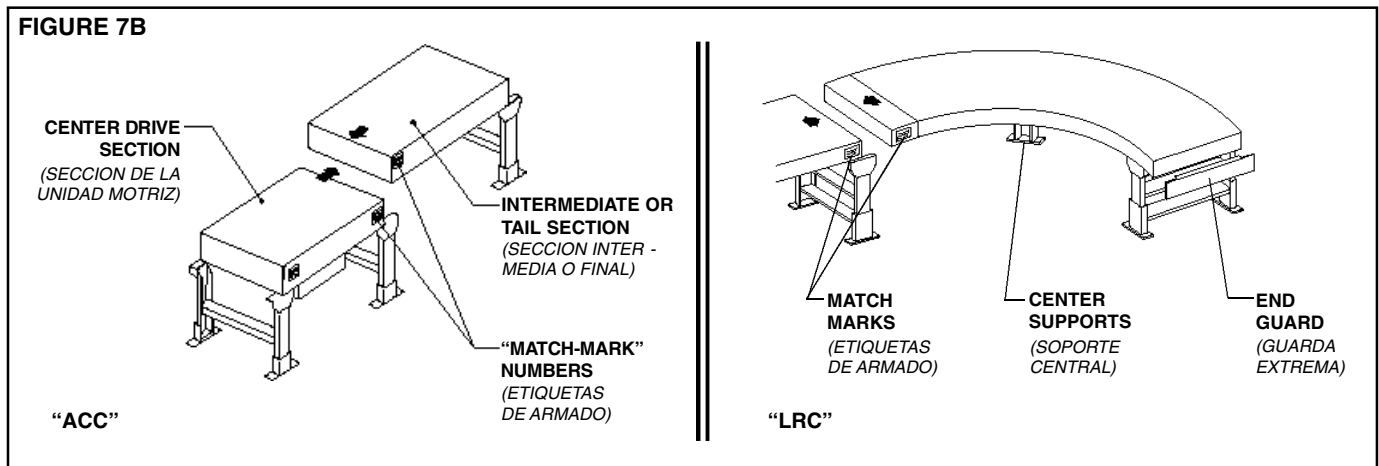
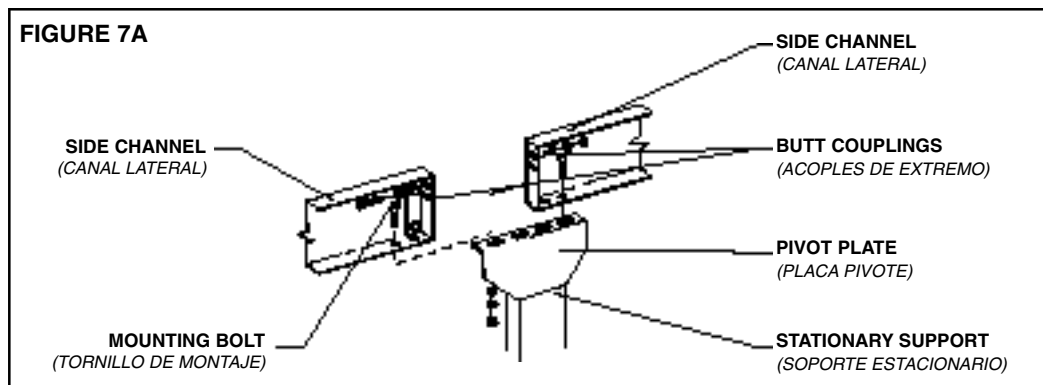
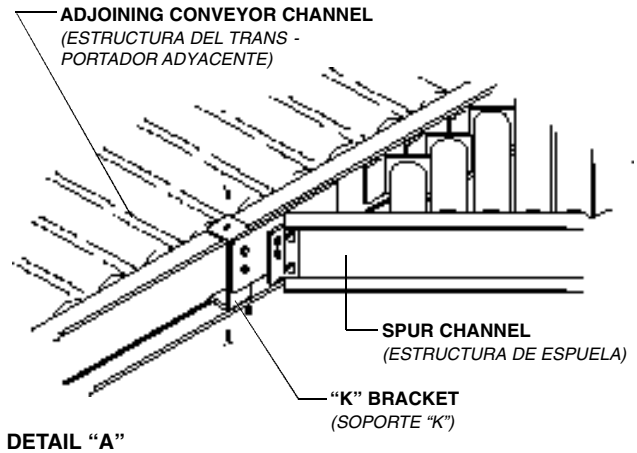
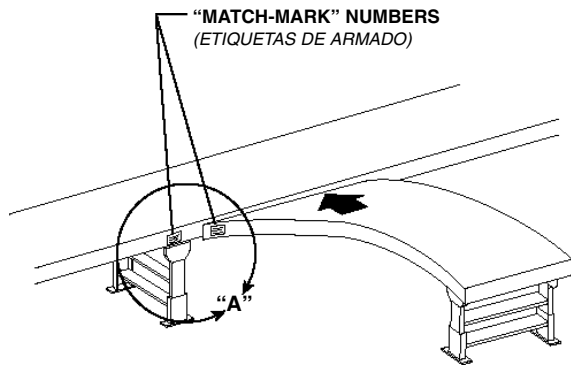

FIGURE 8A



● Connecting the V-Belts—ACC

The double groove sheave, located at one end of each conveyor section, is used to connect the driving V-belts of the conveyor. The groove in which each belt is placed is predetermined at the factory. Refer to Figure 8B.

Beginning with the drive bed section, the drive V-belt is installed in the outside groove of the sheave. From this point on, (in both directions), the belts will alternate from inside to outside groove. (Figure 9A).

Note that take-up sheaves have been installed to align the V-Belt with the respective grooves on the double groove sheaves. (See Figure 9B).

● Conectando las Bandas-V — ACC

La polea de doble ranura de la banda-V, que está ubicada a un lado del transportador, se usa para conectar las bandas-V del transportador. La ranura en que se coloca cada banda se determina en la fabricación. Vea la Figura 8B. Empezando con la sección motriz, la banda-V se coloca en la ranura exterior de la polea. Desde este lugar (en ambas direcciones), las bandas se alternan de interior a exterior (Figura 9A).

Verifique que las poleas tensoras hayan sido instaladas para alinear la banda-V con sus respectivas ranuras en las poleas de doble ranura. (Vea Figura 9B).

FIGURE 8B

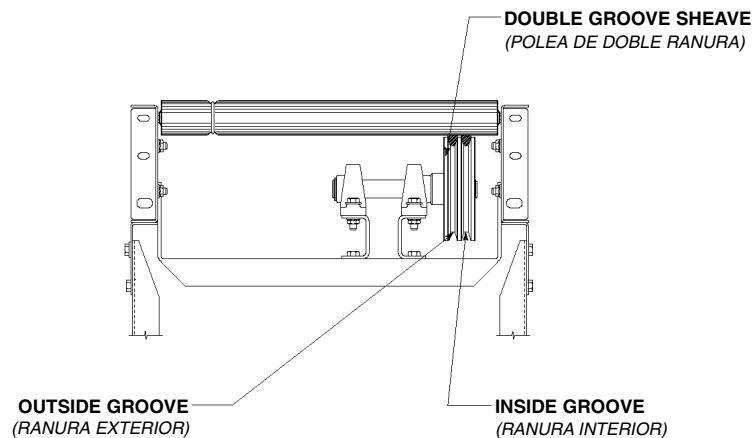

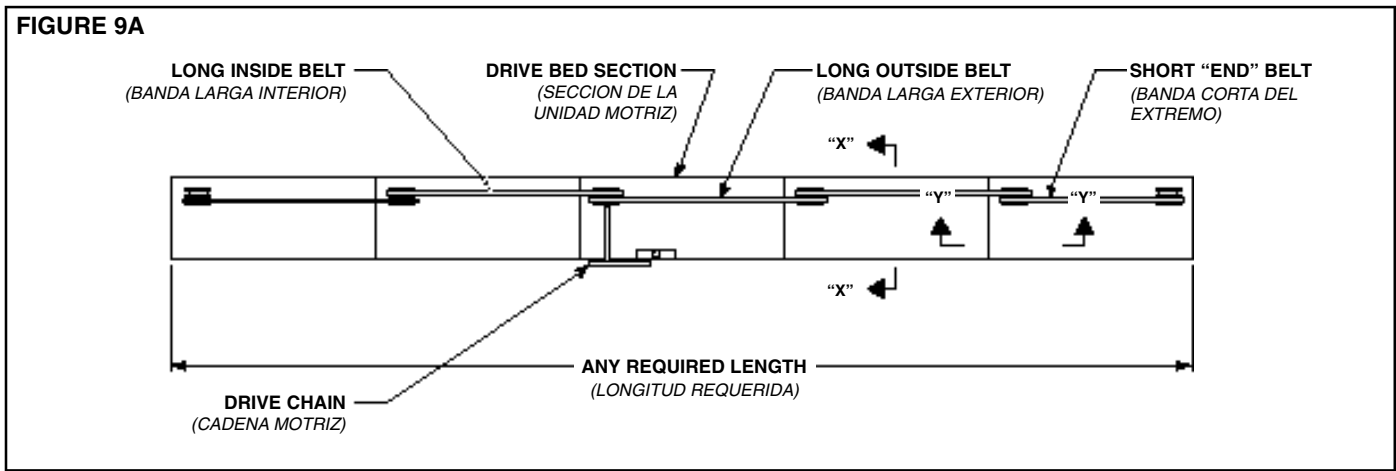

CAUTION!
Under no circumstances, attempt to install any V-belt by operation the drive motor. Personal Injury may occur.

PRECAUCION!
Nunca trate de instalar la banda-V con el motor operando. Puede causar serias lesiones.

TO CONNECT THE V-BELT

1. . . Remove the front cover of the chain guard and disconnect the drive chain. This will free the drive sheave so belts may be installed.
2. . . Remove five tread rollers from both ends of each conveyor section (Figure 9B). This is done by depressing one end of the spring-loaded shaft.
3. . . Note all section with a belt in the outside groove. Install these belts to adjoining sections first. Carefully roll the belts to the outside grooves by rotating the double sheaves.
4. . . Place drive belt over take-up shave located near double groove sheave.
5. . . Install all remaining belts in the inside groove.
6. . . Reconnect the drive chain and replace the front cover of chain guard.
7. . . Replace all tread rollers.

PARA CONECTAR LA BANDA-V

1. . . Remueva la guarda de la cadena y desconecte la cadena motriz. Así se soltará la polea motriz de la banda-V para instalar las bandas.
2. . . Remueva cinco rodillos de ambos lados de cada sección del transportador (Figura 9B). Eso se hace apretando un lado del eje con resorte.
3. . . Defina todas las secciones que tendrán banda en la ranura exterior. Primero instale estas bandas exteriores rotando cuidadosamente la polea doble.
4. . . Coloque la banda motriz sobre la polea tensora ubicada cerca de la polea de doble ranura.
5. . . Instale las bandas restantes en la ranura interior.
6. . . Reconecte la cadena motriz e instale nuevamente la cubierta frontal de la guarda.
7. . . Instale todos los rodillos nuevamente.

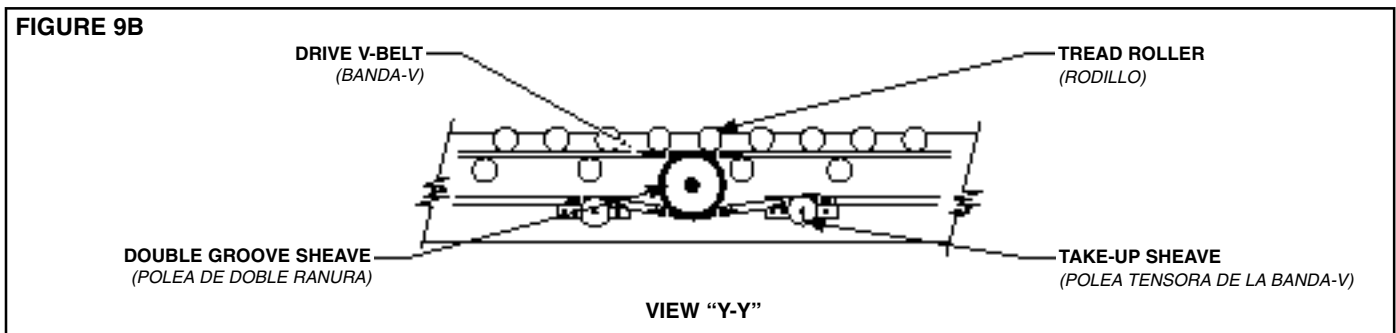

CAUTION!
During installation, do not use tools such as screwdrivers, wrenches, etc., or damage to the V-belts could occur.

PRECAUCION!
Durante la instalación, no use herramientas como desarmadores, llaves inglesas, etc., porque se pueden dañar las bandas-V.

● Racked Sections

It is important that each bed section be checked for an out-of-square condition. If conveyor is not square, tracking problems will result. Figure 10A indicates a racked section.

TO CORRECT AN OUT-OF-SQUARE SECTION

1. . . Locate points on corners of section and measure distance "A" & "B". If the dimensions are not equal, the section will need to be squared. (Figure 10B).
2. . . Use crossbracing supplied on underside of conveyor to square each section. Adjust turnbuckle until Dimensions "A" & "B" are equal.
3. . . After all bed sections have been checked and corrected for "racked condition", tighten all butt couplings and pivot plate bolts.
4. . . Make final check to see that all conveyor sections are level across width and length. If entire conveyor is level, supports can be lagged to floor.

IMPORTANT!

Being out of level width of conveyor can cause package drift on long conveyor lines.

● Secciones Descuadradas

Es importante revisar que las secciones están encuadradas. La Figura 10A muestra una sección descuadrada.

PARA CORREGIR UNA SECCION DESCUADRADA

1. . . Establezca puntos en las esquinas de la sección y mida la distancia "A" y "B". Si las dimensiones no son iguales, la sección necesita ser ajustada (Figura 10B).
2. . . Use el tirante tensor suministrado en la parte inferior del transportador para encuadrar cada sección. Ajuste el tensor hasta que las dimensiones "A" y "B" sean iguales.
3. . . Después de que todas las secciones hayan sido verificadas y corregidas, apriete todos los acoples de extremo y las placas pivote.
4. . . Revise que todas las secciones estén niveladas a lo ancho y largo. Si el transportador está nivelado, los soportes pueden ser anclados al suelo.

¡IMPORTANTE!

El transportador desnivelado a lo ancho puede causar el amontonamiento de cajas en largas líneas de transportación.

FIGURE 10A

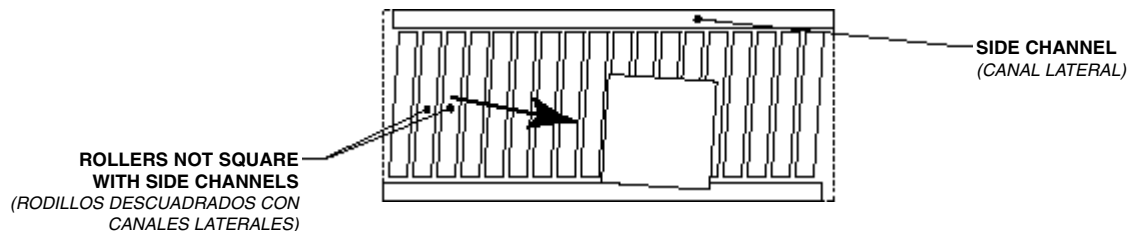

"Racked" conveyor sections will cause package to travel toward side of conveyor.

Secciones descuadradas del transportador hacen que el producto se mueva hacia un lado del transportador.

FIGURE 10B

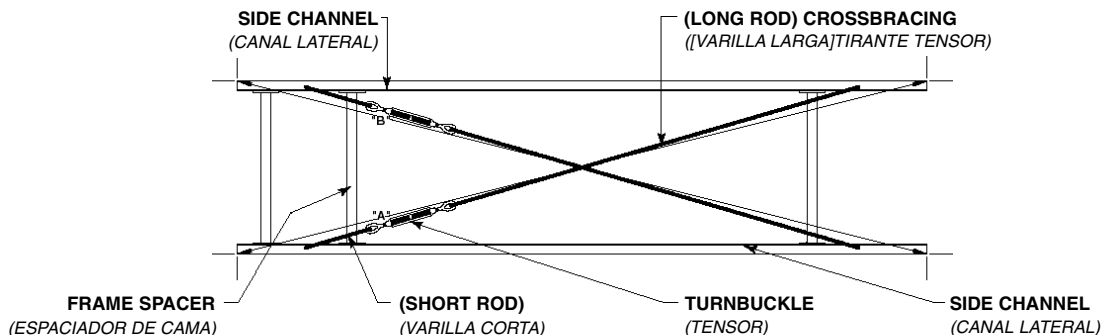

● Slave Driven Curve or Spur

TO INSTALL THE CONNECTING CHAIN

1. . . Remove sprockets and chain guard back plate as necessary so conveyors can be connected together.
2. . . Fasten conveyors together with butt couplings and pivot plates. (Figure 7A, Page 7).
3. . . Attach chain guard back plate to bottom of conveyor frame. (Figure 11A).
4. . . Install sprockets and keys on shafts and align by placing straight edge across the face of both sprockets. Adjust as needed and tighten set screws.
5. . . Install chain around sprockets and insert connecting link. (Figure 12A, Detail "A"). Tighten chain by adjusting take-up block. **NOTE:** If conveying in one direction only, position take-up block on slack side of chain. In conveying in both directions, position take-up block at bottom of chain as shown in Figures 11A and 12A.
6. . . Install chain guard front plate.

● Curva o Espuela Motriz Esclavada

COMO INSTALAR LA CADENA IMPULSADORA

1. . . Remueva las catarinas y la cubierta de la guarda de cadena para poder conectar los dos transportadores.
2. . . Junte los transportadores con las placas pivote y de unión (Figura 7A, Página 7).
3. . . Una la cubierta interior de la guarda con la parte de abajo de la estructura (Figura 11A).
4. . . Instale las catarinas y los candados de los ejes y alínelos en frente de las dos catarinas. Ajuste como sea necesario y apriete los tornillos.
5. . . Ponga la cadena alrededor de las catarinas e inserte el conector de cadena (Figura 12A, Detalle "A"). Apriete la cadena ajustando el bloque tensor. **NOTA:** Si el transportador corre en una sola dirección, ponga el bloque tensor en el lado flojo de la cadena. Si corre en ambas direcciones, ponga el bloque debajo de la cadena como se muestra en Figuras 11A y 12A.
6. . . Coloque la placa frontal de la guarda cadena.

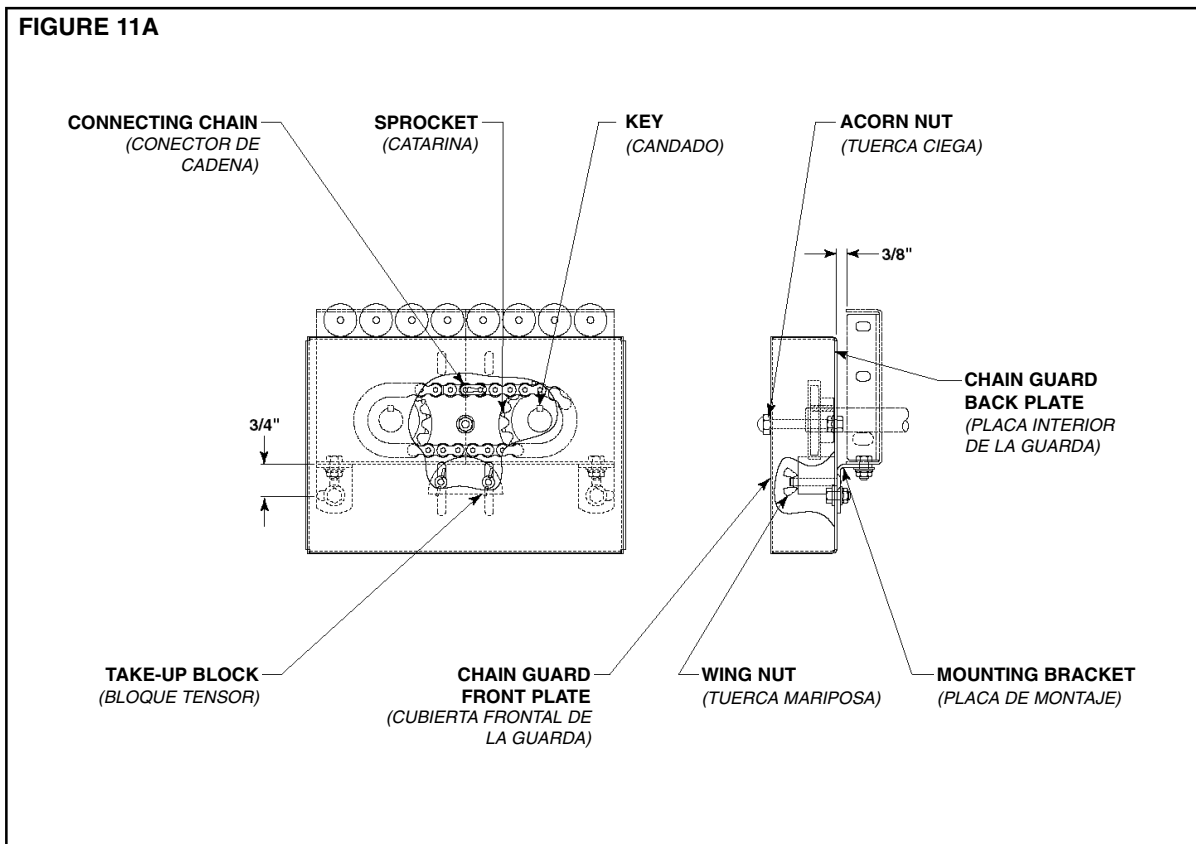
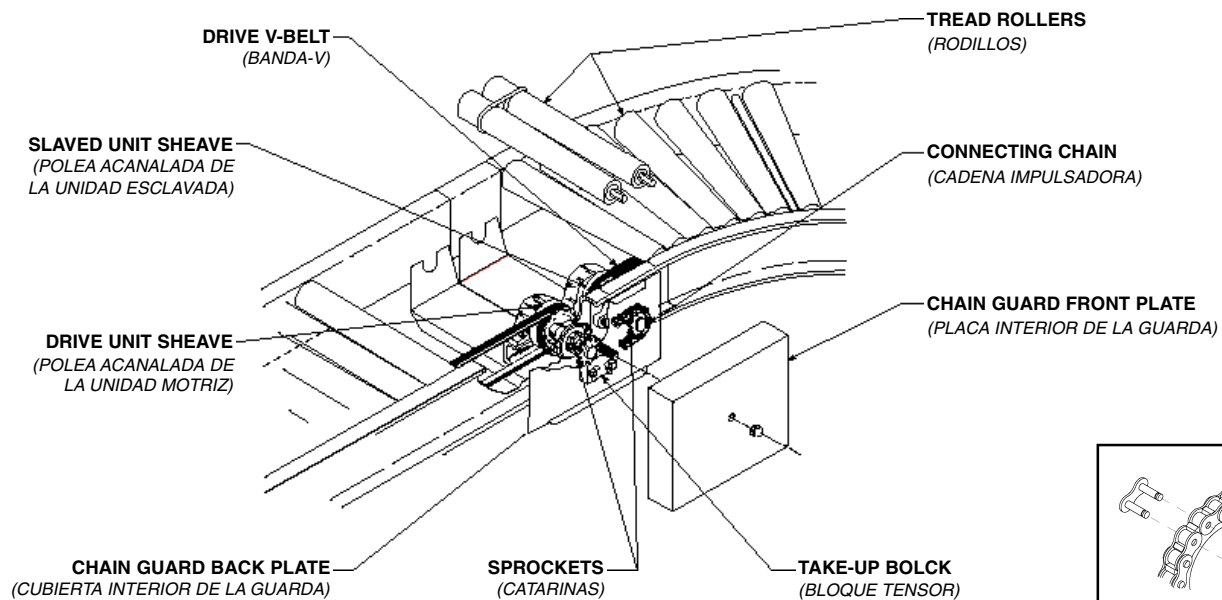

FIGURE 12A



● Pressure Adjustment

MODEL "ACC" (Figure 13A)

The "ACC" is equipped with suspension angles that support the pressure rollers and hold the drive V-belt in contact with the tread rollers. Knurled nuts allow the conveyor to be finely adjusted for minimum pressure accumulation. To make this adjustment, follow the steps listed below.

1. . . With conveyor running, reduce pressure on all tread rollers to zero by loosening the knurled adjustment nuts.
2. . . Place heaviest item to be conveyed on infeed end of conveyor, Increase pressure under the item by tightening the knurled nuts. Apply only enough pressure to barely move the item.
3. . . As the item moves, continue adjustment ahead of item until it moves the entire length of conveyor.
4. . . Return item to infeed end of unit. It should now travel the entire length of conveyor. If not, repeat the adjustment procedure in the problem area.

● Ajuste de Presión

MODELO "ACC" (Figura 13A)

El Modelo "ACC" viene con ángulos de suspensión que sostienen los rodillos de presión y mantienen la banda-V motriz en contacto con los rodillos de transportación. Las tuercas de ajuste permiten que el transportador se ajuste adecuadamente para una acumulación mínima. Para hacer este ajuste, siga los siguientes pasos.

1. . . Con el transportador en movimiento, reduzca la presión a los rodillos de transportación aflojando las tuercas de ajuste.
2. . . Ponga la caja u objeto más pesado, en el extremo de la carga. Aumente la presión apretando las tuercas de ajuste. Aplique la presión suficiente para que el objeto se empiece a mover.
3. . . Mientras el objeto se mueve, continúe el ajuste de presión en frente del objeto hasta que recorra todo el largo del transportador.
4. . . Regrese el objeto al extremo de carga. Este debe recorrer todo el transportador. Si no, repita el ajuste en el área del problema.

NOTE: Do not apply more pressure than necessary to move the heaviest package.

NOTA: No aplique más presión de la que sea necesaria para mover el objeto más pesado.

MODEL “LRC”, “LRS”, & “LRSS” (Figure 13B)

Curves and spurs have snub sheaves that hold the drive V-belt in contact with its tread rollers. Adjustments are made by moving the snub sheaves up or down in the slotted conveyor channel.

When making adjustments, apply only enough force to move the heaviest item to be conveyed.

MODELOS “LRC”, “LRS”, & “LRSS” (Figura 13B)

Curvas y espuelas tienen poleas de retorno que mantienen la banda-V motriz en contacto con sus rodillos de trans - portación. Los ajustes se hacen moviendo las poleas verti - calmente en el canal ranurado del transportador.

Para hacer ajustes, aplique solamente la presión suficiente para mover el objeto más pesado.

CAUTION!
Snubbing the belt too much can cause the conveyor to stall.

PRECAUCION!
Apretar la banda demasiado puede causar que el transportador se detenga.

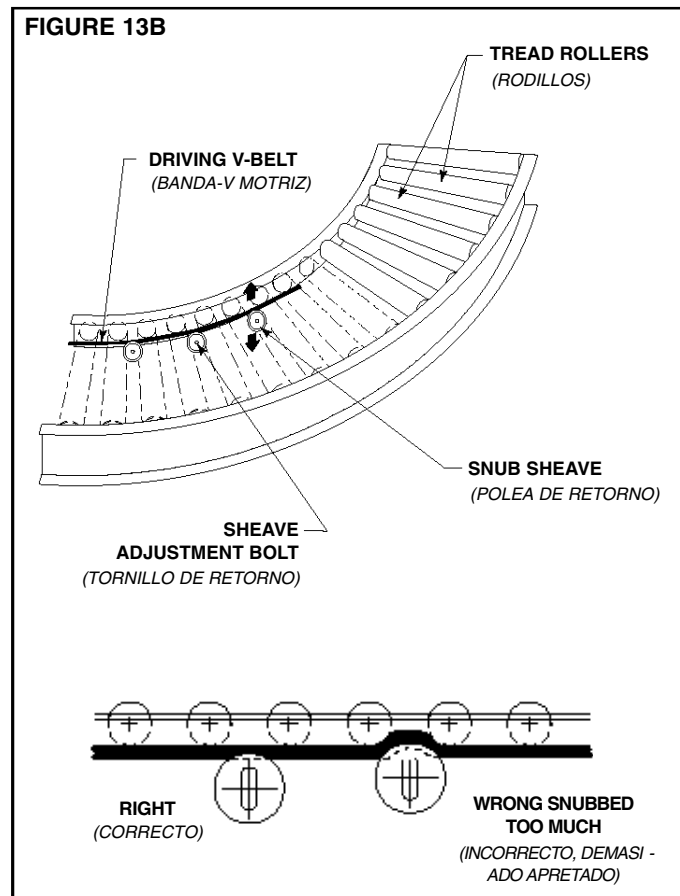
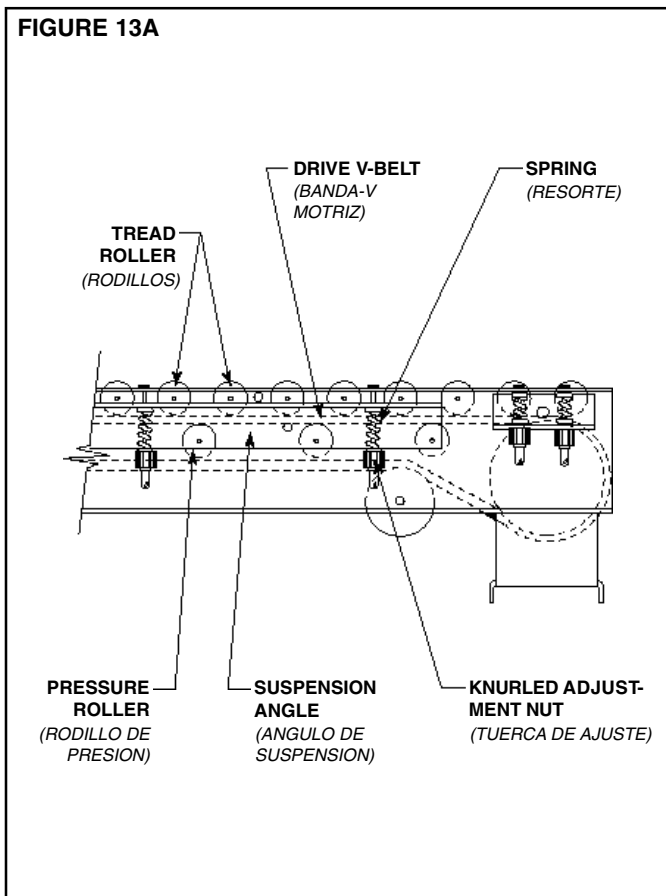



● Electrical Equipment

WARNING!

Electrical controls shall be installed and wired by a qualified electrician. Wiring information for the motor and controls are furnished by the equipment manufacturer.

CONTROLS

Electrical Code: All motor controls and wiring shall conform to the National Electrical Code (Article 670 or other applicable articles) as published by the National Fire Protection Association and as approved by the American Standards Institute, Inc.

CONTROL STATIONS

A) Control stations should be so arranged and located that the operation of the equipment is visible from them, and shall be clearly marked or labeled to indicate the function controlled.

B) A conveyor which would cause injury when started shall not be started until employees in the area are alerted by a signal or by a designated person that the conveyor is about to start.

When a conveyor would cause injury when started and is automatically controlled or must be controlled from a remote location, an audible device shall be provided which can be clearly heard at all points along the conveyor where personnel may be present. The warning device shall be actuated by the controller device starting the conveyor and shall continue for a required period of time before the conveyor starts. A flashing light or similar visual warning may be used in conjunction with or in place of the audible device if more effective in particular circumstances.

Where system function would be seriously hindered or adversely affected by the required time delay or where the intent of the warning may be misinterpreted (i.e., a work area with many different conveyors and allied devices), clear, concise, and legible warning shall be provided. The warning shall indicate that conveyors and allied equipment may be started at any time, that danger exists, and that personnel must keep clear. The warnings shall be provided along the conveyor at areas not guarded by position or location.

C) Remotely and automatically controlled conveyors, and conveyors where operator stations are not manned or are beyond voice and visual contact from drive areas, loading areas, transfer points, and other potentially hazardous locations on the conveyor path not guarded by location, position, or guards, shall be furnished with emergency stop buttons, pull cords, limit switches, or similar emergency stop devices.

● Equipo Eléctrico

ADVERTENCIA!

Los controles eléctricos deben ser conectados e instalados por un electricista calificado. La información sobre el cableado del motor y los controles será proporcionada por el fabricante del equipo.

CONTROLES

Código Eléctrico: Todos los controles del motor y las conexiones deben ajustarse al National Electrical Code (Artículo 670 u otros artículos aplicables) como fue publicado por la National Fire Protection Association y aprobado por el American Standards Institute, Inc.

ESTACIONES DE CONTROL

A) Las estaciones de control deberán estar arregladas y ubicadas de tal forma que el funcionamiento del equipo sea visible y deberán estar claramente marcadas o señaladas para indicar la función controlada.

B) Un transportador que pueda causar lesiones cuando es puesto en marcha, no deberá ponerse a funcionar hasta que los trabajadores en el área sean alertados por una señal o por una persona designada que indique que el transportador está a punto de arrancar.

Cuando un transportador pueda causar lesiones al arrancar y es automáticamente controlado, o tiene que ser controlado desde una ubicación lejana, se deberá proporcionar un dispositivo sonoro el cual pueda ser escuchado claramente en todos los puntos a lo largo del transportador donde el personal pueda estar presente. El dispositivo de advertencia deberá ser activado por el dispositivo de arranque del transportador, y deberá continuar sonando por un determinado periodo de tiempo antes de que el transportador empiece a funcionar. Una luz intermitente o una advertencia visual similar puede ser utilizada con o en lugar del dispositivo sonoro si es más efectivo en circunstancias particulares.

Donde el funcionamiento del sistema pudiera ser seriamente obstruido o adversamente afectado por el tiempo de retardo requerido, o donde el intento de advertencia pueda ser mal interpretado (ej., un área de trabajo con diversas líneas de transportadores y los dispositivos de advertencia relacionados), advertencias claras, concisas y legibles deberán ser proporcionadas. Las advertencias deberán indicar que los transportadores y los equipos relacionados pueden ser puestos en marcha en cualquier momento, que existe un peligro y que el personal debe mantenerse alejado. Estas advertencias deben ser proporcionadas a lo largo del transportador en áreas que no sean protegidas por la posición o la ubicación.

C) Los transportadores controlados automáticamente o desde estaciones lejanas, y los transportadores donde las estaciones de funcionamiento no estén controladas por una persona, o

All such emergency stop devices shall be easily identifiable in the immediate vicinity of such locations unless guarded by location, position, or guards. Where the design, function, and operation of such conveyor clearly is not hazardous to personnel, an emergency stop device is not required.

The emergency stop device shall act directly on the control of the conveyor concerned and shall not depend on the stopping of any other equipment. The emergency stop devices shall be installed so that they cannot be overridden from other locations.

D) Inactive and unused actuators, controllers, and wiring should be removed from control stations and panel boards, together with obsolete diagrams, indicators, control labels, and other material which serve to confuse the operator.

SAFETY DEVICES

A) All safety devices, including wiring of electrical safety devices, shall be arranged to operate in a “Fail-Safe” manner, that is, if power failure or failure of the device itself would occur, a hazardous condition must not result.

B) *Emergency Stops and Restarts.* Conveyor controls shall be so arranged that, in case of emergency stop, manual reset or start at the location where the emergency stop was initiated, shall be required of the conveyor(s) and associated equipment to resume operation.

C) Before restarting a conveyor which has been stopped because of an emergency, an inspection of the conveyor shall be made and the cause of the stoppage determined. The starting device shall be locked out before any attempt is made to remove the cause of stoppage, unless operation is necessary to determine the cause or to safely remove the stoppage.

Refer to ANSI Z244.1-1982, American National Standard for Personnel Protection – Lockout/Tagout of Energy Sources – Minimum Safety Requirements and OSHA Standard Number 29 CFR 1910.147 “The Control of Hazardous Energy (Lockout/Tagout).”

estén mas allá del alcance de la voz y del contacto visual de las áreas de conducción, áreas de carga, puntos de transferencia y otros sitios potencialmente peligrosos localizados en la trayectoria del transportador que no tenga protección, ya sea dada por posición, ubicación, o guardas, deberán ser equipados con interruptores de parada de emergencia, cor-dones de parada de emergencia, interruptores de límite o dispositivos similares para paradas de emergencia.

Todos estos dispositivos de parada de emergencia deberán ser fácilmente identificables en las cercanías inmediatas a estos puntos potencialmente peligrosos, a no ser que estén protegidos dada su ubicación, posición o protegidos con guardas. Donde el diseño, el funcionamiento, y la operación de tales transportadores no represente un claro peligro para el personal, un dispositivo de parada de emergencia no es requerido.

El dispositivo de parada de emergencia deberá actuar directamente en el control del transportador concerniente y no deberá depender de la parada de cualquier otro equipo. Los dispositivos de parada de emergencia deberán ser instalados de tal forma que no puedan ser anulados desde otras localidades.

D) *Los dispositivos, controles inactivos y no usados, y cables, deberán ser removidos de las estaciones de control y de los tableros de mando, junto con los diagramas, indicadores, etiquetas de control y otros materiales obsoletos, los cuales se prestan para confundir al operador.*

DISPOSITIVOS DE SEGURIDAD

A) *Todos los dispositivos de seguridad, incluyendo la conexión de dispositivos eléctricos, deben ser dispuestos para operar en una manera de “autoprotección”; es decir, si se presenta una pérdida de corriente o un fallo en el mismo dispositivo, no debe presentarse una situación peligrosa.*

B) *Paradas de Emergencia y Reactivadores.* Los controles del transportador deberán estar dispuestos de tal manera que, en caso de una parada de emergencia, se requerirá un activador o arrancador manual en la ubicación donde la parada de emergencia se presentó para reanudar la operación del transportador o transportadores y el equipo asociado.

C) *Antes de volver a poner en marcha un transportador que haya sido detenido por una emergencia, debe revisarse y determinar la causa de la parada. El dispositivo de arranque deberá ser asegurado antes de intentar corregir o remover la causa que originó la parada, a no ser que la operación del transportador sea necesaria para determinar la causa o para remover sin peligro la causa de la parada.*

Refiérase a ANSI Z244.1-1982, American National Standard for Personnel Protection - Lockout/Tagout of Energy Sources - Minimum Safety Requirements and OSHA Standard Number 29 CFR 1910.147 “The Control of Hazardous Energy (Lockout/Tagout).”



● Operation Safety Precautions

- A)** Only trained employees shall be permitted to operate conveyors. Training shall include instruction in operation under normal conditions and emergency situations.
- B)** Where employee safety is dependent upon stopping and/or starting devices, they shall be kept free of obstructions to permit ready access.
- C)** The area around loading and unloading points shall be kept clear of obstructions which could endanger personnel.
- D)** No person shall ride the load-carrying element of a conveyor under any circumstances unless that person is specifically authorized by the owner or employer to do so. Under those circumstances, such employee shall only ride a conveyor which incorporates within its supporting structure, platforms or control stations specifically designed for carrying personnel. Under no circumstances shall any person ride on any element of a vertical conveyor. Owners of conveyors should affix warning devices to the conveyor reading **Do Not Ride Conveyor**.
- E)** Personnel working on or near a conveyor shall be instructed as to the location and operation of pertinent stopping devices.
- F)** A conveyor shall be used to transport only material it is capable of handling safely.
- G)** Under no circumstances shall the safety characteristics of the conveyor be altered if such alterations would endanger personnel.
- H)** Routine inspections and preventive and corrective maintenance programs shall be conducted to insure that all safety features and devices are retained and function properly.
- I)** Personnel should be alerted to the potential hazard of entanglement in conveyors caused by items such as long hair, loose clothing, and jewelry.
- J)** As a general rule, conveyors should not be cleaned while in operation. Where proper cleaning requires the conveyor to be in motion and a hazard exists, personnel should be made aware of the associated hazard.

● Conveyor Start-Up

Before conveyor is turned on, check for foreign objects that may have been left inside conveyor during installation. These objects could cause serious damage during start-up. After conveyor has been turned on and is operating, check motors, reducers, and moving parts to make sure they are working freely.

CAUTION!

Because of the many moving parts on the conveyor, all personnel in the area of the conveyor need to be warned that the conveyor is about to be started.

● Medidas de Seguridad en la Operación

- A)** Solo se debe permitir operar los transportadores a empleados entrenados. El entrenamiento debe incluir instrucciones de operación bajo condiciones normales y en situaciones de emergencia.
- B)** Donde la seguridad de los trabajadores dependa de dispositivos de parada y/o arranque, éstos deberán mantenerse libres de obstrucciones para permitir un acceso rápido.
- C)** El área alrededor de los puntos de carga y descarga debe mantenerse libre de obstrucciones, las cuales podrían poner en peligro al personal.
- D)** Ninguna persona debe montarse en la parte de conducción de carga de un transportador bajo ninguna circunstancia al menos que esta persona esté específicamente autorizada por el dueño o por el empleado encargado. Bajo estas circunstancias, el empleado deberá montarse solamente en un transportador que tenga incorporado dentro de su estructura, plataformas o estaciones de control especialmente diseñadas para el traslado de personal. Bajo ninguna circunstancia, persona alguna debe subirse a cualquier parte de un transportador vertical. Los dueños de los transportadores deben añadir señales de advertencia al transportador con el texto: "No Montarse en el Transportador".
- E)** El personal que esté trabajando en, o cerca al transportador, deberá ser instruido en cuanto a la ubicación y operación de los dispositivos pertinentes de parada.
- F)** Un transportador deberá ser usado para transportar solo el producto que es capaz de manejarlo seguramente.
- G)** Bajo ninguna circunstancia deberán ser alteradas las características de seguridad de un transportador, si tales alteraciones pudieran poner en peligro al personal.
- H)** Inspecciones rutinarias deberán llevarse a cabo al igual que programas preventivos y correctivos de mantenimiento, para asegurar que todos los dispositivos y medidas de seguridad sean conservados en buen estado y funcionen correctamente.
- I)** El personal deberá ser avisado de peligros potenciales como enredos en transportadores causados por materiales como pelo largo, ropa suelta o joyas.
- J)** Como regla general, los transportadores no deberán limpiarse mientras estén en funcionamiento. Cuando se requiera limpiar el transportador estando en movimiento y exista posibilidad de peligro, el personal deberá ser avisado de este posible riesgo.

● Arranque del Transportador

Antes de poner en marcha el transportador, revise si hay objetos ajenos que puedan haber sido dejados dentro del transportador durante la instalación. Estos objetos pueden causar serios daños en el arranque. Después de que el transportador arranque y esté operando, verifique los motores, reductores y partes en movimiento para estar seguro de que están trabajando libremente.

PRECAUCION!

Debido a la cantidad de partes en movimiento en el transportador, todo el personal en el área del transportador necesita ser advertido de que este está a punto de ponerse en marcha.

● Maintenance Safety Precautions

- A) Maintenance, such as lubrication and adjustments, shall be performed only by qualified and trained personnel.
- B) It is Important that a maintenance program be established to insure that all conveyor components are maintained in a condition which does not constitute a hazard to personnel.
- C) When a conveyor is stopped for maintenance purposes, starting devices or powered accessories shall be locked or tagged out in accordance with a formalized procedure designed to protect all person or groups involved with the conveyor against an unexpected start.
- D) Replace all safety devices and guards before starting equipment for normal operation.
- E) Whenever practical, **DO NOT** lubricate conveyors while they are in motion. Only trained personnel who are aware of the hazard of the conveyor in motion shall be allowed to lubricate.

SAFETY GUARDS

Maintain all guards and safety devices **IN POSITION** and **IN SAFE REPAIR**.

WARNING SIGNS

Maintain all warning signs in a legible condition and obey all warnings. See Page 3 of this manual for examples of warning signs.

● Lubrication

The drive chain is pre-lubricated from the manufacturer by a hot dipping process that ensures total lubrication of all components. However, continued proper lubrication will greatly extend the useful life of every drive chain.

Drive Chain lubrication serves several purposes including:

- Protecting against wear of the pin-bushing joint
- Lubricating chain-sprocket contact surfaces
- Preventing rust or corrosion

For normal operating environments, lubricate every 2080 hours of operation or every 6 months, whichever comes first. Lubricate with a good grade of non-detergent petroleum or synthetic lubricant (i.e., Mobile 1 Synthetic). For best results, always use a brush to generously lubricate the chain. The proper viscosity of lubricant greatly affects its ability to flow into the internal areas of the chain. Refer to the table below for the proper viscosity of lubricant for your application.

Ambient Temperature Degrees F	SAE	ISO
20-40	20	46 or 68
40-100	30	100
100-120	40	150

The drive chain's lubrication requirement is greatly affected by the operating conditions. For harsh conditions such as damp environments, dusty environments, excessive speeds, or elevated temperatures, it is best to lubricate more frequently. It may be best, under these conditions, to develop a custom lubrication schedule for your specific application. A custom lubrication schedule may be developed by inspecting the drive chain on regular time intervals for sufficient lubrication. Once the time interval is determined at which the chain is not sufficiently lubricated, lubricate it and schedule the future lubrication intervals accordingly.

● Medidas de Seguridad en el Mantenimiento

- A) El mantenimiento, tal como lubricación y ajustes, debe ser realizado solamente por personal calificado y entrenado.
- B) Es importante que se establezca un programa de mantenimiento, para asegurar que todos los componentes del transportador sean mantenidos en condiciones que no constituyan un peligro para el personal.
- C) Cuando un transportador esté parado por razones de mantenimiento, los dispositivos de arranque o accesorios motorizados deberán ser asegurados o desconectados conforme a un procedimiento formalizado, diseñado para proteger de cualquier arranque inesperado a toda persona o grupos de personas involucrados con el transportador.
- D) Antes de poner en marcha el equipo, vuelva a colocar todos los dispositivos de seguridad y las guardas.
- E) Siempre que sea práctico, **NO** lubrique los transportadores mientras se encuentren en movimiento. Solo el personal entrenado, que tenga conocimiento de los peligros del transportador en movimiento, se le permitirá lubricarlos de esta manera.

PROTECCIONES DE SEGURIDAD

Mantenga todas las guardas y dispositivos de seguridad **EN SU POSICION** y **EN BUENAS CONDICIONES**.

SEÑALES DE ADVERTENCIA

Mantenga todas las señales de advertencia en condiciones legibles y obedézcalas. Remítase a la página 3 de este manual para ver ejemplos de señales de advertencia.

● Lubricación

La cadena motriz ha sido pre-lubricada por el fabricante mediante un proceso de sumersión caliente que asegura una lubricación total de todos sus componentes. Sin embargo, una lubricación apropiada y continua extenderá su vida útil considerablemente.

La lubricación de la cadena motriz cumple varios propósitos:

- Proteger contra el desgaste de la unión de pines de la cadena
- Lubricar las superficies de contacto entre la cadena y la catarina
- Prevenir la oxidación o corrosión.

En operaciones bajo condiciones ambientales normales, lubrique cada 2080 horas de operación o cada 6 meses, lo que ocurra primero. Lubrique con un lubricante sintético (ej. Mobile 1 sintético) o basado en petróleo no-detergente de buen grado. Para mejores resultados, siempre utilice una brocha para lubricar la cadena generosamente. La viscosidad apropiada del lubricante afecta enormemente el fluido del mismo hacia las áreas internas de la cadena. Refiérase a la siguiente tabla para consultar la viscosidad de lubricante adecuada para su aplicación.

Temperatura Ambiente (Grados F°) (Grados C°)	SAE	ISO
20-40 -07 - 04	20	46 o 68
40-100 04 - 38	30	100
100-120 38 - 49	40	150

El requerimiento de lubricación de la cadena motriz se ve afectado considerablemente por las condiciones de operación. En condiciones difíciles tales como: ambientes húmedos, ambientes con polvo, velocidades excesivas, o temperaturas elevadas, se recomienda lubricar la cadena con más frecuencia. Lo mejor sería que bajo estas condiciones se establezca un programa de lubricación específico para su aplicación. Este programa específico puede desarrollarse mediante la inspección de la lubricación suficiente de la cadena motriz en intervalos regulares de tiempo. Una vez se ha determinado el intervalo en el cual la cadena no se encuentra suficientemente lubricada, lubríquela y programe los siguientes intervalos de acuerdo al intervalo anterior.

● Belt Replacement

MODEL "ACC"

1. . . Check length of section in which belt is to be replaced.
2. . . Determine if a "long" or "short" belt is needed. (Figure 19A).
3. . . See Parts List for correct replacement number, Pages 26 & 27. See **NOTES** in page 19.

TO REPLACE BELT

1. . . Using knurled nuts, lower belt away from tread rollers in section belt is being replaced.
2. . . Remove five tread rollers from each end of section.
3. . . Remove all pressure rollers.
4. . . Replace belt and all rollers.
5. . . Adjust accumulating pressure per instructions on Page 12.

MODEL "LRC", "LRS" , & "LRSS"

1. . . Check Overall Frame Width (OAW) (Figure 19B).
2. . . Determine degree of curve or spur.
3. . . See respective Parts List for correct replacement number, Pages 28 thru 42. See **NOTES** in page 19.

TO REPLACE BELT

1. . . Note how old belt is installed.
2. . . Remove all tread rollers.
3. . . Replace belt and all rollers.
4. . . Adjust belt tension per instructions on Page 20.

CAUTION!

During installation, do not use tools such as screwdrivers, wrenches, etc., or damage to the V-belts could occur.

● Reemplazo de la Banda

MODELO "ACC"

1. . . *Revise el largo de la sección en la que se repone la banda.*
2. . . *Determine si se necesita una banda larga o corta (Figura 19A).*
3. . . *Vea en la Lista de Partes el número correcto de la refacción, páginas 26 y 27. Vea las **Notas** página 19.*

PARA REEMPLAZAR LA BANDA

1. . . *Usando las tuercas de ajuste, baje la banda de los rodillos de transportación en la sección donde se repone la banda.*
2. . . *Remueva los cinco rodillos de transportación en ambos lados de la sección.*
3. . . *Remueva todos los rodillos de presión.*
4. . . *Reemplace la banda y coloque todos los rodillos.*
5. . . *Ajuste la presión de acumulación según las instrucciones en Página 12*

MODELO "LRC", "LRS" , & "LRSS"

1. . . *Revise el Ancho Total del Marco (OAW) (Figura 19B).*
2. . . *Determine el ángulo de la curva o espuela.*
3. . . *Vea en la Lista de Partes respectiva el número correcto de la refacción, Páginas 28 a la 42. Vea las **Notas** en la página 19.*

PARA REEMPLAZAR LA BANDA

1. . . *Observe como está puesta la banda.*
2. . . *Remueva todos los rodillos de transportación.*
3. . . *Reemplace la banda y coloque los rodillos.*
4. . . *Ajuste la tensión de la banda según las instrucciones en Página 20.*

PRECAUCION!

Durante la instalación no use herramientas como desarmadores, llaves inglesas, etc., porque se pueden dañar las bandas-V.

FIGURE 19A

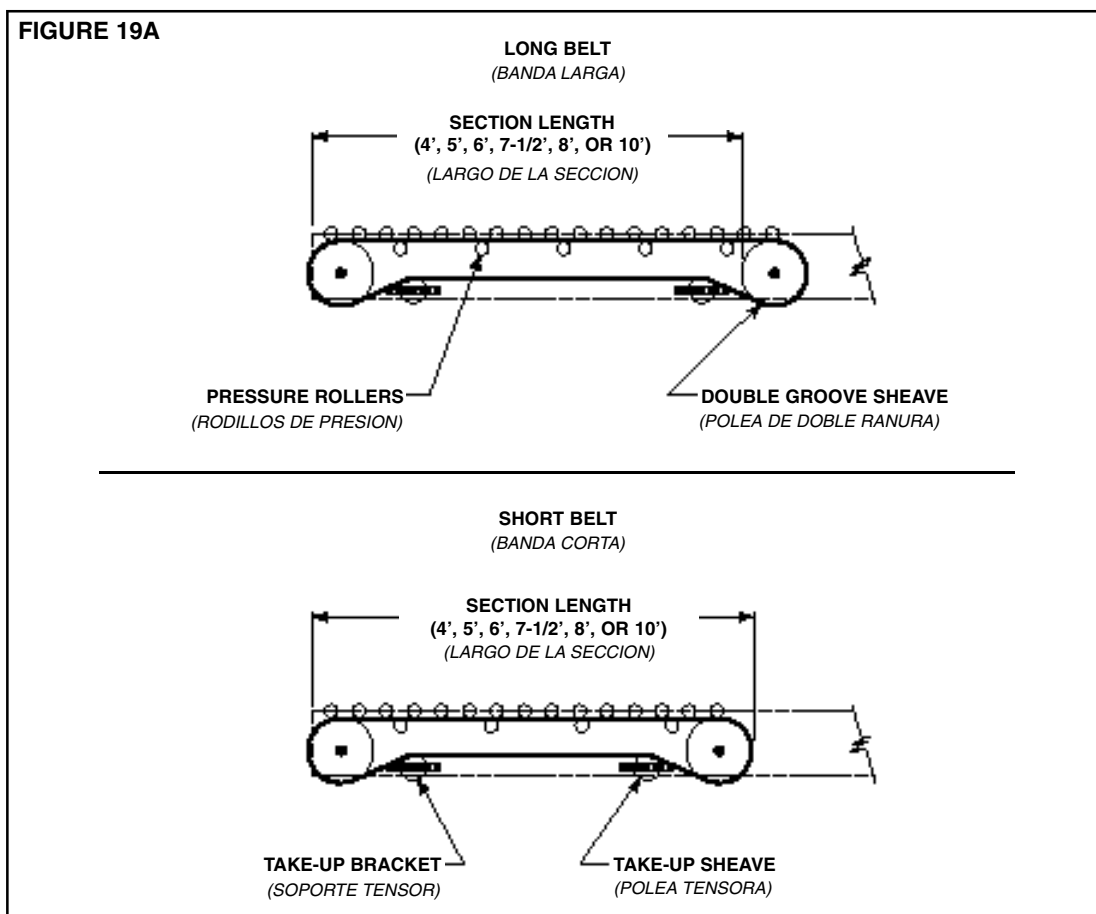
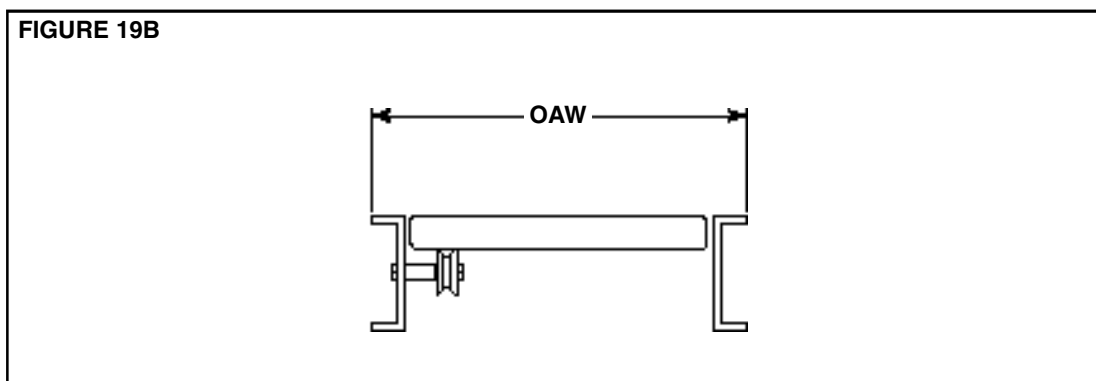

FIGURE 19B



NOTE: Special length V-belts are used on the "ACC" & "LRSS" conveyors. It is recommended that replacement be obtained from HYTROL. The Models "LRC" & "LRS" use standard "B" section industrial grade V-belts (Non-Glass Core). these belts may either be purchased from HYTROL or local suppliers.

NOTA: Longitudes especiales de bandas-V son usadas en los transportadores "ACC" & "LRSS". Se recomienda obtener el repuesto en HYTROL. Los Modelos "LRC" & "LRS" usan bandas-V tipo industrial de sección "B" estándar (Núcleo Sin-Vidrio). Estas bandas pueden comprarse en HYTROL o con distribuidores locales.

● Belt Tension Adjustment

MODEL "ACC"

Take-up brackets with sheaves are located at both ends of conveyor section to adjust belt tension. (Figure 19A). To tighten belt, remove take-up sheave and re-position in another hole closer to double groove sheave. To loosen belt, move take-up sheave in opposite direction.

NOTE: it is recommended that both take-up sheaves be moved when making adjustments.

MODEL "LRC" & "LRS"

The Models "LRC" & "LRS" have a take-up bracket located near the center on the underside of the conveyor. To adjust the belt tension, loosen the jam nuts on the take-up screw and move take-up sheave as indicated in Figure 20A.

MODEL "LRSS"

Belt take-up is provided at the spur (pointed) end of the Model "LRSS". (Figure 20B). To adjust, loosen mounting bolt and move sheave until proper tension is reached. Re-tighten mounting bolt.

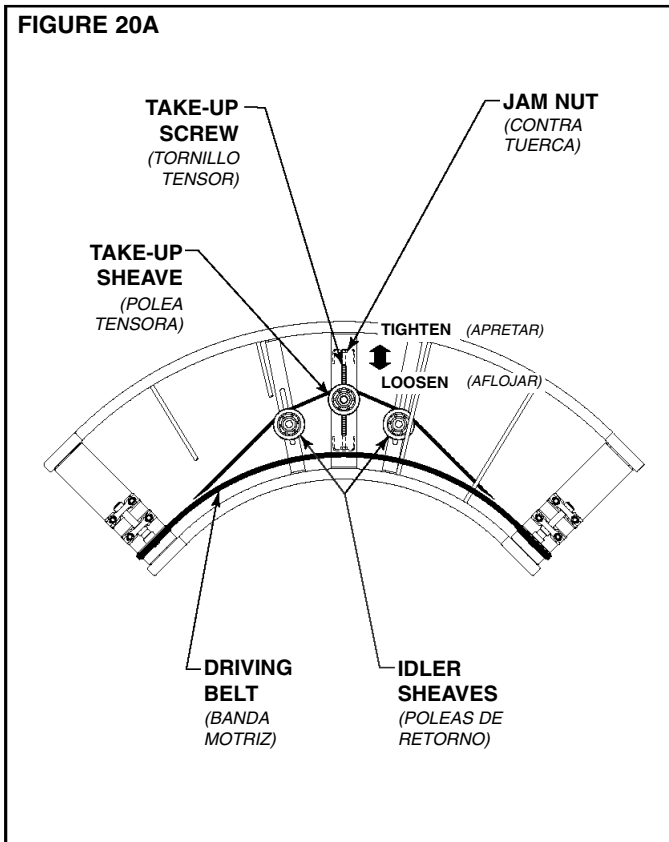

● Tensión de la Banda

MODELO "ACC"

Los soportes con poleas están ubicados en ambos lados de la sección del transportador para ajustar la tensión de la banda (Figura 19A). Para apretar la banda, remueva la polea tensora y reubique en otra perforación mas cercana a la polea de banda-V. Para aflojar la banda, mueva la polea tensora en la dirección contraria.

NOTA: Es recomendable que ambas poleas tensoras se muevan cuando se hagan ajustes.

MODELO "LRC" & "LRS"

Los Modelos "LRC" & "LRS" tienen un soporte tensor ubicado en la parte inferior del transportador cerca del centro. Para ajustar la tensión de la banda, afloje las contra tuercas en el tornillo tensor y mueva la polea tensora como se muestra en la Figura 20A.

MODELO "LRSS"

El tensor de la banda se encuentra en el extremo del Modelo "LRSS" (Figura 20B). Para ajustar, afloje el tornillo de montaje y mueva la polea hasta alcanzar la tensión apropiada. Apriete nuevamente el tornillo.

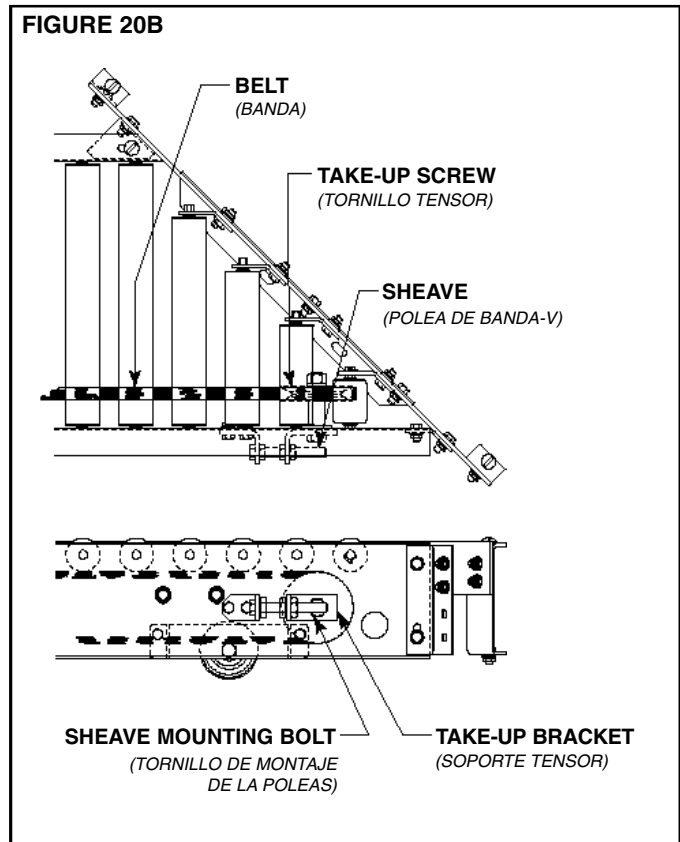

● Drive Chain Alignment and Tension

The drive chain and sprockets should be checked periodically for proper tension and alignment. Improper adjustment will cause extensive wear to the drive components.

TO MAKE ADJUSTMENTS

1. . . Remove chain guard.
2. . . Check sprocket alignment by placing a straightedge across the face of both sprockets (Figure 21A). Loosen set screws and adjust as needed. Re-tighten set screws.
3. . . To adjust chain tension, loosen bolts that fasten motor base to mounting angles, both sides of the conveyor. Tighten take-up bolts until desired chain tension is reached. (Figures 21B & 21C). Re-tighten mounting bolts.
4. . . Lubricate chain per lubrication instructions.
5. . . Replace chain guard so that it does not interfere with drive.

● Alineación y Tensión de la Cadena Motriz

La cadena motriz y las catarinas deberán ser revisadas periódicamente para mantener su apropiada tensión y alineación. Ajustes incorrectos causarán un desgaste excesivo a los componentes de la transmisión.

PARA HACER AJUSTES

1. . . Remueva la guarda cadena.
2. . . Verifique la alineación de las catarinas colocando un nivel sobre las caras de ambas catarinas. (Figura 21A). Afloje los tornillos candados y ajuste tanto como sea necesario. Apriete los tornillos candados.
3. . . Para ajustar la tensión de la cadena, afloje los tornillos que aseguran la base del motor a los ángulos de montaje, a ambos lados del transportador. Apriete los tornillos tensores hasta obtener la tensión correcta de la cadena (Figuras 21B & 21C). Apriete los tornillos de montaje.
4. . . Lubrique la cadena de acuerdo a las instrucciones de lubricación.
5. . . Coloque la guarda de cadena para que no interfiera con la transmisión.

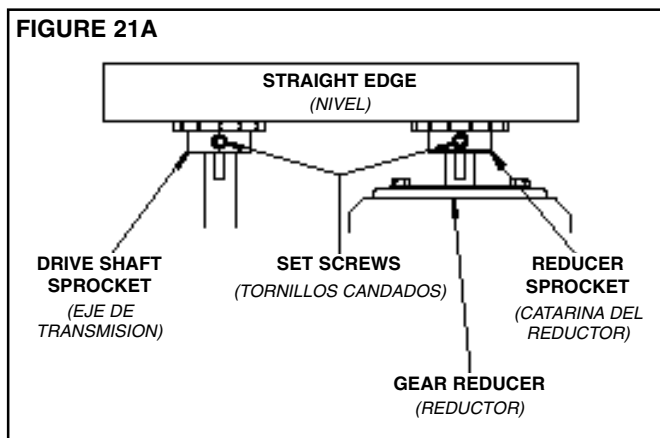

CAUTION!

Never remove chain guards while the conveyor is running. Always replace guards after adjustments are made.

PRECAUCION!

Nunca remueva la guarda de cadena mientras el transportador esté en funcionamiento. Siempre vuelva a colocar las guardas después de que se hayan hecho los ajustes.

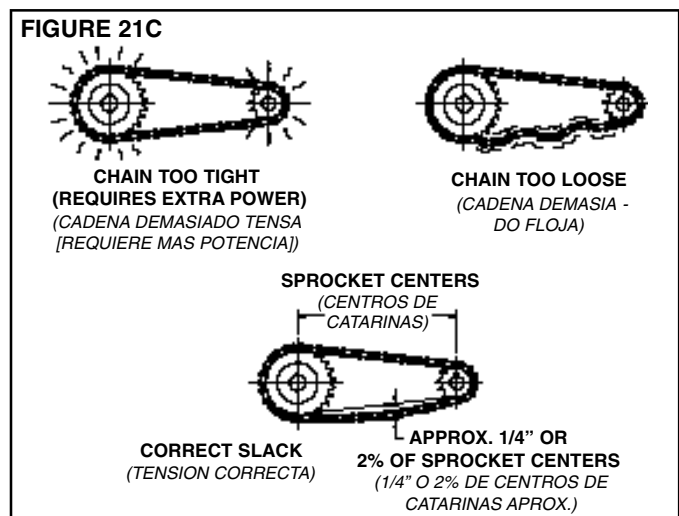
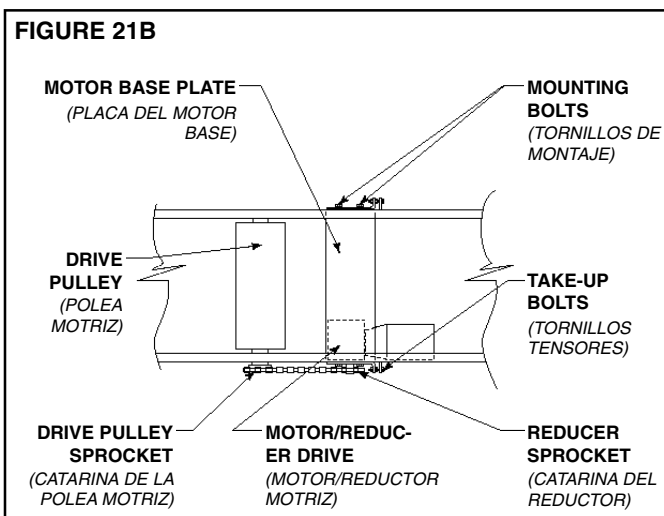



● Trouble Shooting

The following charts list possible problems that may occur in the operation of a powered conveyor.

TROUBLE SHOOTING DRIVES

TROUBLE	CAUSE	SOLUTION
Conveyor will not start or motor quits frequently.	<ol style="list-style-type: none"> 1) Motor is overloaded. 2) Motor is drawing too much current. 	<ol style="list-style-type: none"> 1) Check for overloading of conveyor. 2) Check heater or circuit breaker and change if necessary.
Drive chain and sprockets wear excessively.	<ol style="list-style-type: none"> 1) Lack of lubrication on chain causing chain stretch which creates improper chain to sprocket mesh. 2) Sprockets are out of alignment. 3) Loose chain. 	<ol style="list-style-type: none"> 1) Replace chain and sprockets. Provide adequate lubrication. NOTE: If problem reoccurs, a chain take-up may be required. 2) Align sprockets. See "Drive Chain Alignment and Tension". 3) Tighten chain.
Loud popping or grinding noise.	<ol style="list-style-type: none"> 1) Defective bearing. 2) Loose set screws in bearing. 3) Loose drive chain. 	<ol style="list-style-type: none"> 1) Replace bearing. 2) Tighten set screw. 3) Tighten chain.
Motor or reducer overheating.	<ol style="list-style-type: none"> 1) Conveyor is overloaded. 2) Low voltage to motor. 3) Low lubricant level in reducer. 	<ol style="list-style-type: none"> 1) Check capacity of conveyor and reduce load to recommended level. 2) Have electrician check and correct as necessary. 3) Relubricate per manufacturer's recommendations. For HYTROL reducer, refer to separate manual.

TROUBLE SHOOTING DRIVE BELT TRACKING

TROUBLE	CAUSE	SOLUTION
Belt slips or won't move, but drive runs.	<ol style="list-style-type: none"> 1) Conveyor is overloaded 2) Belt too loose. 3) Too much pressure against belt from pressure rollers 	<ol style="list-style-type: none"> 1) Check capacity of conveyor and reduce load to recommended level. 2) Re-position take-up sheaves in hole closer to double groove sheaves. 3) Loosen spring tension on pressure rollers in area of stalled rollers. See "Minimum Pressure Adjustment" in Operation section of this manual.
Belt moving, but tread rollers not turning.	<ol style="list-style-type: none"> 1) Not enough pressure against belt from pressure rollers. 2) Bolt in the pressure roller suspension angle binding will not allow adjustment of pressure rollers. 3) Missing or broken springs or adjustment nuts. 	<ol style="list-style-type: none"> 1) Tighten spring tension on pressure rollers in area of stalled rollers. See "Minimum Pressure Adjustment" in Operation section of this manual. 2) Loosen bolt and adjust spring tension as required. Check for burrs or foreign material behind angles. 3) Replace and re-adjust.

● Resolviendo Problemas

Los siguientes cuadros describen posibles problemas que pueden ocurrir en la operación de un transportador motorizado.

RESOLVIENDO PROBLEMAS DE TRANSMISION

PROBLEMA	CAUSA	SOLUCION
El transportador no arranca o el motor se detiene frecuentemente.	<ol style="list-style-type: none"> 1) El motor está sobrecargado. 2) El motor pasa demasiada corriente. 	<ol style="list-style-type: none"> 1) Revise si hay sobrecarga del transportador. 2) Revise los circuitos e interruptores de protección y sobrecarga, y cámbielos si es necesario.
Desgaste excesivo de la cadena motriz y las catarinas.	<ol style="list-style-type: none"> 1) Falta de lubricación en la cadena causando su extensión lo cual crea una cadena inapropiada. 2) Los catarinas están desalineadas. 3) La cadena está floja. 	<ol style="list-style-type: none"> 1) Reemplaze la cadena y las catarinas. Proporcione una adecuada lubricación. NOTA: Si se presentan problemas, posiblemente se requiere tensionar la cadena. 2) Alinee catarinas. Vea "Alineación y Tensión de Cadena Motriz". 3) Tensione la cadena.
Funcionamiento muy ruidoso.	<ol style="list-style-type: none"> 1) Rodamientos defectuosos. 2) El tornillo candado está flojo. 3) La cadena está floja. 	<ol style="list-style-type: none"> 1) Reemplaze los baleros. 2) Apriete el tornillo candado. 3) Tensione la cadena.
Motor o reductor recalentado.	<ol style="list-style-type: none"> 1) Transportador está sobrecargado. 2) Bajo voltaje al motor. 3) Bajo nivel de lubricante en reductor. 	<ol style="list-style-type: none"> 1) Revise la capacidad del transportador y reduzca la carga al nivel recomendado. 2) Haga un chequeo por un electricista y corrija si es necesario. 3) Vuelva a lubricar de acuerdo a las recomendaciones del fabricante. Para el reductor HYTROL, refiérase al manual adjunto.

RESOLVIENDO PROBLEMAS DE ALINEACION DE LA BANDA MOTRIZ

PROBLEMA	CAUSA	SOLUCION
La banda se desliza o no se mueve pero el motor corre	<ol style="list-style-type: none"> 1) El transportador está sobrecargado. 2) La banda está floja. 3) Hay demasiada presión contra la banda por los rodillos de presión. 	<ol style="list-style-type: none"> 1) Revise la capacidad del transportador y reduzca la carga al nivel recomendado. 2) Reubique las poleas tensoras en una perforación mas cercana a las poleas de doble ranura. 3) Afloje la tensión de la tuerca de ajuste en el área de los rodillos parados. Vea "Ajuste de Presión Mínima" en la sección de Operación de este manual.
La banda corre pero los rodillos no.	<ol style="list-style-type: none"> 1) No hay suficiente presión contra la banda por los rodillos de presión. 2) El tornillo en el ángulo de suspensión no deja que se ajusten los rodillos de presión. 3) Hay resortes o tornillos de ajuste perdidos o rotos. 	<ol style="list-style-type: none"> 1) Apriete las tuercas de ajuste en el área de los rodillos parados. Vea "Ajuste de Presión Mínima" en la sección de Operación de este manual. 2) Afloje el tornillo y ajuste tensión del resorte como sea necesario. Revise si hay material o suciedad detrás de los ángulos. 3) Reemplaze y ajuste nuevamente.

● Preventive Maintenance Checklist

The following is a general maintenance checklist which covers the major components of your conveyor.

This will be helpful in establishing a standard maintenance schedule.

COMPONENT	SUGGESTED ACTION	SCHEDULE		
		Weekly	Monthly	Quarterly
MOTOR	Check Noise			
	Check Temperature			
	Check Mounting Bolts			
REDUCER	Check Noise			
	Check Temperature			
	Check Oil Level			
BEARINGS (Pulleys & Rollers)	Check Noise			
	Check Mounting Bolts			
DRIVE CHAIN	Check Tension			
	Lubricate			
	Check for Wear			
SPROCKETS	Check for Wear			
	Check Set Screws & Keys			
V-BELTS	Check Tension			
	Check for Wear			
	Check for Sheave Alignment			
STRUCTURAL	General Check: All loose bolts, etc., tightened			

● Lista de Mantenimiento Preventivo

La siguiente es una lista de verificación del mantenimiento preventivo la cual cubre principales componentes de su

transportador. Esta será útil para establecer un programa de mantenimiento estándar.

COMPONENTE	REMEDIO	HORARIO		
		Semanal	Mensual	Trimestral
MOTOR	Revisar Ruido			
	Revisar la Temperatura			
	Revisar los Tornillos de Montaje			
REDUCTOR	Revisar Ruido			
	Revisar la Temperatura			
	Revisar el Nivel de Aceite			
RODAMIENTOS (Poleas & Rodillos)	Revisar Ruido			
	Revisar los Tornillos de Montaje			
CADENA MOTRIZ	Revisar Ruido			
	Lubricar			
	Revisar el Desgaste			
CATARINAS	Revisar el Desgaste			
	Revisar los Tornillos de Montaje			
BANDAS-V	Revisar la Tensión			
	Revisar el Desgaste			
	Revisar la Alineación de la Polea			
ESTRUCTURAL	Revisión General: Tornillos flojos, etc.			

● How to Order Replacement Parts

Included in this manual are parts drawings with complete replacement parts lists. Minor fasteners, such as nuts and bolts, are not included.

When ordering replacement parts:

1. . . Contact Dealer from whom conveyor was purchased or nearest HYTROL Distributor.
2. . . Give Conveyor Model Number and Serial Number or HYTROL Factory Order Number.
3. . . Give Part Number and complete description from Parts List.
4. . . Give type of drive. Example—8" End Drive, 8" Center Drive, etc.
5. . . If you are in a breakdown situation, tell us.



**HYTROL Serial Number
(Located near Drive on
Powered Models).**

● Como Ordenar Partes de Repuesto

Incluido en este manual hay dibujos de las partes con listas completas de las refacciones. Aseguradores menores, como tornillos y tuercas no están incluidos.

Para ordenar partes de repuesto:

1. . . *Contacte el vendedor que le vendió el transportador o el distribuidor de Hytrol más cercano.*
2. . . *Comunique el Modelo del Transportador y el Número de Serie o Número de la Orden de Planta.*
3. . . *Comunique el Número de las partes y descripción completa de la Lista de Partes.*
4. . . *Diga el tipo de motor. Ejemplo—8" Unidad Motriz en el Extremo, 8" Unidad Motriz Central, etc.*
5. . . *Si está en una situación crítica, comuníquese inmediatamente.*



**Número de Serie HYTROL
(Localizado cerca de la
Unidad Motriz en los
modelos motorizados).**

● Model 138-ACC Parts Drawing

Dibujo de Partes del Modelo 138-ACC

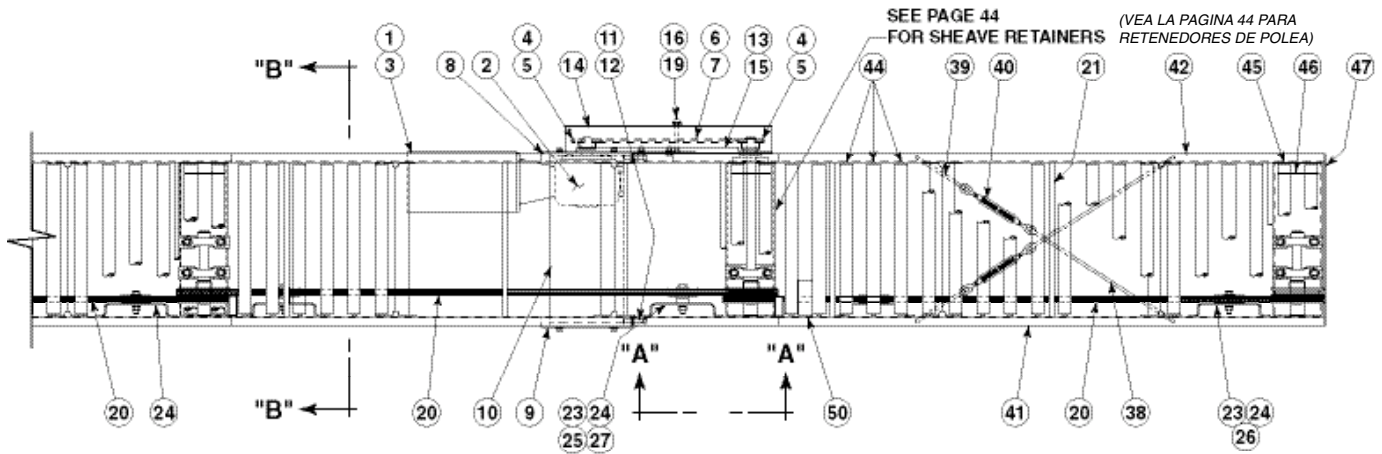

SEE PAGE 44
FOR SHEAVE RETAINERS
(VEA LA PAGINA 44 PARA
RETENEDORES DE POLEA)

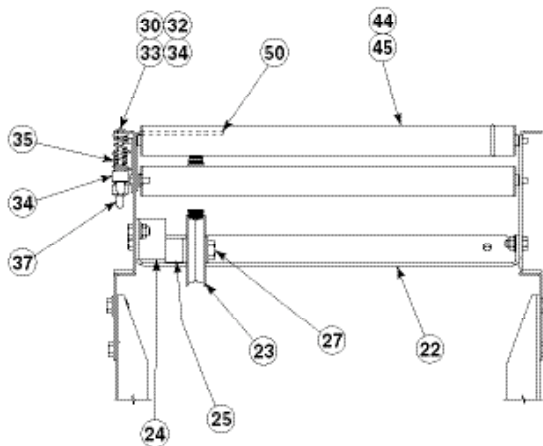
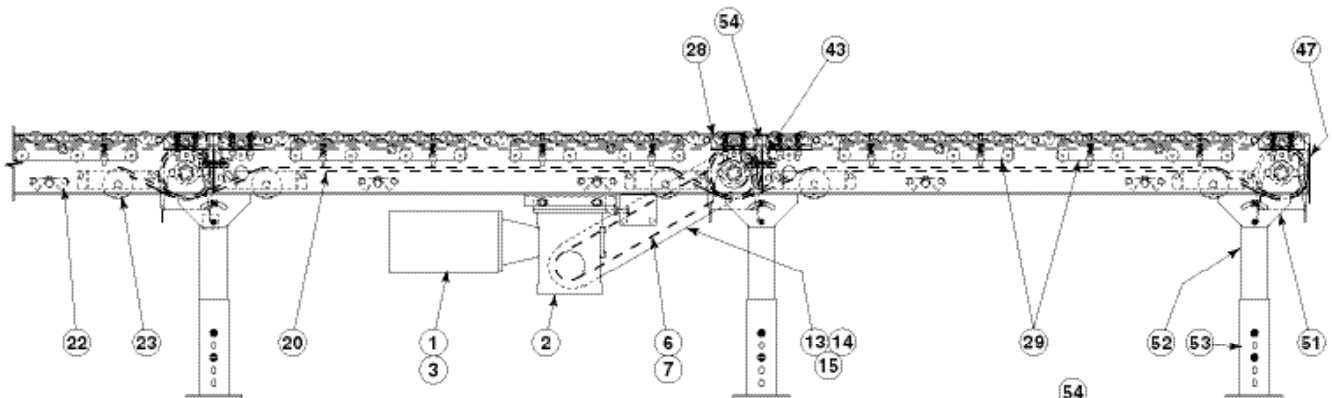

SECTION "B-B"
(SECCION "B-B")

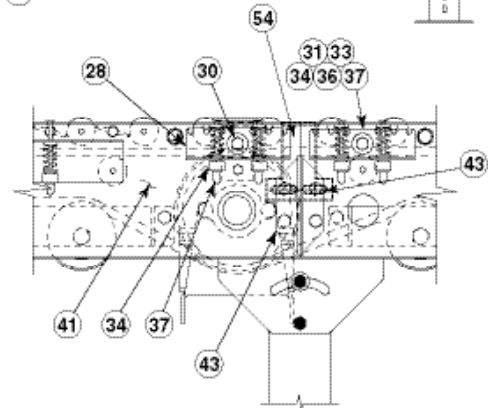

VIEW "A-A"
(VISTA "A-A")

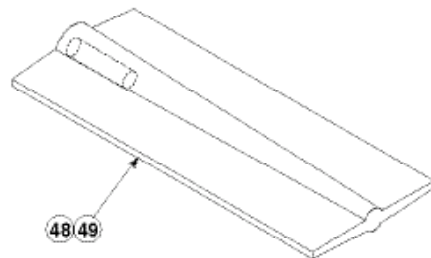

*See Page 46 for Slave Connection
(*Vea la Página 46 para la Conexión Esclavada)

● Model 138-ACC Parts List

Lista de Partes del Modelo 138-ACC



See Page 25 for Information on How To
Order Replacement Parts

Ve la Página 25 para información sobre como
ordenar partes de repuesto

Recommended Spare Parts Highlighted In Gray

Partes de Repuesto Recomendadas
se Resaltan en Gris

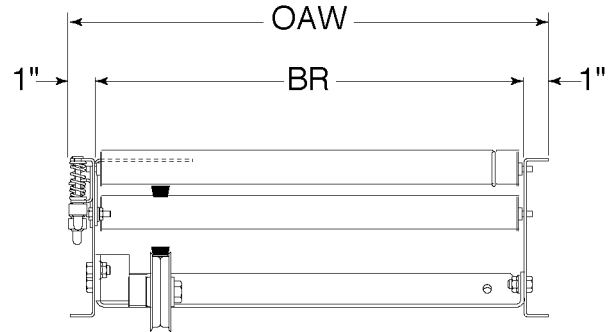

Ref. No.	Part No.	Description
1	—	Motor—C-Face
—	030.7134	1/2 Hp—230/460 VAC—3 Ph.—60 Hz.—TEFC
2	—	4AC Speed Reducer
—	R-00153-40R	RH—40:1 Ratio
—	R-00153-40L	LH—40:1 Ratio
3	052.145	Coupling Kit—Motor to Reducer (1/2 - 3/4 HP)
4	028.119	Sprocket—50B13 x 1 in. Bore
5	090.203	Shaft Key—1/4 in. Sq. x 1 in. Bore
6	029.101	#50 Riveted Roller Chain
7	029.201	Connector Link—#50 Roller Chain
8	B-15008	Motor Base Support Angle—LH
9	B-15009	Motor Base Support Angle—RH
10	B-06629	Motor Base Assembly (Specify OAW)
11	040.307	Take-Up Bolt—3/8-16 x 2-1/4 in. Long
12	041.300	Hex Jam Nut—Heavy—3/8-16
13	B-21222	Chain Guard Back Plate
14	B-21223	Chain Guard Front Plate
15	B-14492	Chain Guard Mounting Angle
16	040.31115	Hex Head Bolt—3/8-16 x 3-1/4 in. Long
19	041.919	Acorn Nut—3/8-16
20	—	(Drive)
—	066.141	4 ft. Section—Long Belt
—	066.147	4 ft. Section—Short Belt
—	066.140	5 ft. Section—Long Belt
—	066.146	5 ft. Section—Short Belt
—	066.139	6 ft. Section—Long Belt
—	066.145	6 ft. Section—Short Belt
—	066.138	7-1/2 ft. Section—Long Belt
—	066.144	7-1/2 ft. Section—Short Belt
—	066.137	8 ft. Section—Long Belt
—	066.138	8 ft. Section—Short Belt
—	066.136	10 ft. Section—Long Belt
—	066.142	10 ft. Section—Short Belt
21	B-05477	Threaded Section Spacer (Specify BR)
22	B-03916	Bed Spacer (Specify BR)
23	024.133	Flat Idler Sheave—3-1/4 in. O.D. x 1/2 in. Bore
24	B-04177	Snub Return Idler Bracket
25	098.167	Spacer—33/64 in. I.D. x 1-1/4 in O.D. x 3/4 in. Long
26	040.404	Hex Head Cap Screw—1/2-13 x 2 in. Long
27	040.406	Hex Head Cap Screw—1/2-13 x 3 in. Long
28	B-04119	Suspension Angle—End Roller
29	—	Suspension Angle
—	B-02459	3-Roller
—	B-02460	4-Roller
30	042.914	Shoulder Bolt—Suspension Angle
31	042.550	Carriage Bolt—1/4-20 x 2-3/4 in. Long
32	042.551	Carriage Bolt—1/4-20 x 3-1/2 in. Long

Ref. No.	Part No.	Description
33	043.400	Finishing Washer—#12
34	041.901	Adjustment Nut—Suspension Angle
35	093.106	Spring—Roller Suspension
36	093.1285	Spring—End Roller Suspension
37	090.220	Red Vinyl Plastisol Cap
38	044.120	Cross Brace Rod—70 in. Long
39	044.121	Cross Brace Rod—6 in. Long
40	049.308	Turnbuckle
41	—	Frame Channel—LH
—	B-15957	4 ft. Long
—	B-15958	5 ft. Long
—	B-15959	6 ft. Long
—	B-15960	7-1/2 ft. Long
—	B-15961	8 ft. Long
—	B-15962	10 ft. Long
42	—	Frame Channel—RH
—	B-15969	4 ft. Long
—	B-15970	5 ft. Long
—	B-15971	6 ft. Long
—	B-15972	7-1/2 ft. Long
—	B-15973	8 ft. Long
—	B-15974	10 ft. Long
43	B-14756	Butt Coupling
44	B-03935	1-3/8 in. Dia. Roller (Specify BR)
45	B-06533	1-3/8 in. Dia. Roller One Groove (Specify BR)
46	090.2549	O-Ring—1/8 in. Dia.
47	B-09799	End Guard (Specify OAW)
48	092.159	V-Belt Shield
49	049.317	Self Tapping Hex Screw—1/4 in. Dia. x 3/4 in. Long
50	B-15441	Nip Point Guard
51	—	MS Type Pivot Plate—1-1/2 in. Flange
—	G-00248	4 in. High
—	G-00249	1-7/8 in. High
52	—	Floor Support Frame
—	B-00914	6 in. High (Specify OAW)
—	B-12777	7 in. High (Specify OAW)
—	B-12778	8 in. High (Specify OAW)
—	B-00915	9 in. High (Specify OAW)
—	B-00916	11-1/2 in. High (Specify OAW)
—	B-00917	14-1/2 in. High (Specify OAW)
—	B-02098	18-1/2 in. High (Specify OAW)
—	B-00919	22-1/2 in. High (Specify OAW)
—	B-00921	32-1/2 in. High (Specify OAW)
—	B-00923	44-1/2 in. High (Specify OAW)
—	B-00925	56-1/2 in. High (Specify OAW)
—	B-02107	68-1/2 in. High (Specify OAW)
—	B-02109	78-1/2 in. High (Specify OAW)
—	B-02111	90-1/2 in. High (Specify OAW)
53	B-00911	Adjustable Foot Assembly (Specify Length)
54	PT-085265	V-Belt Shield (Joint)

● Model 138-LRC 90° Parts Drawing
 Dibujo de Partes del Modelo 138-LRC 90°

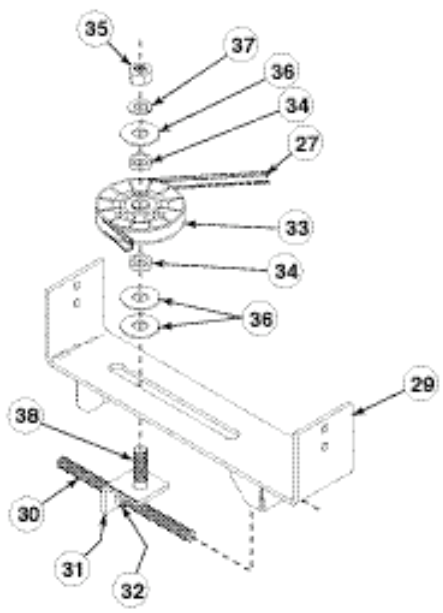
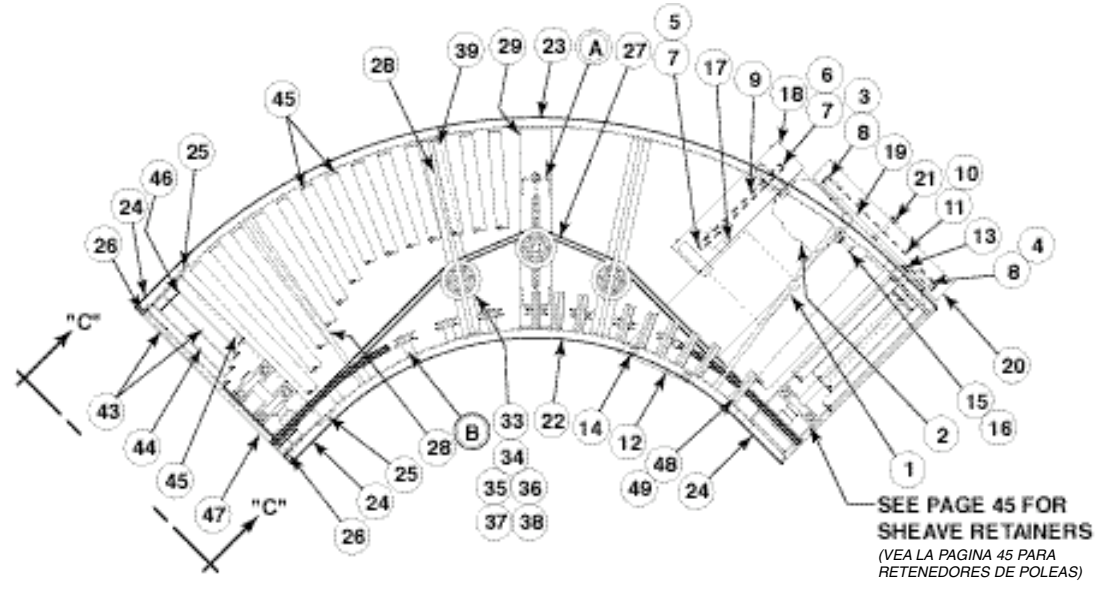

DETAIL "A"
 (DETALLE "A")

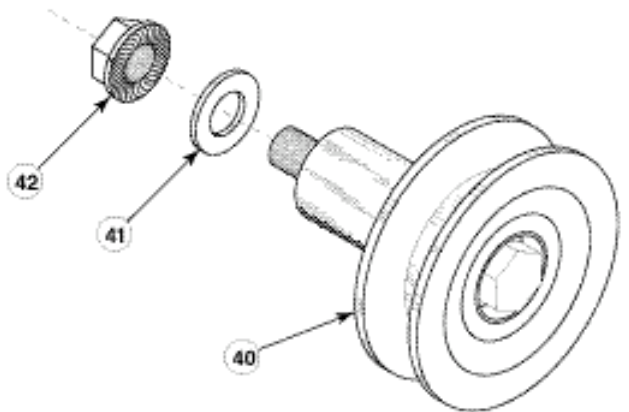

DETAIL "B"
 (DETALLE "B")

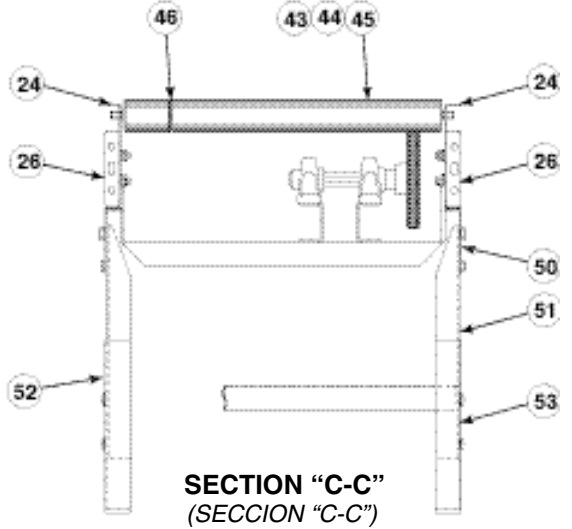
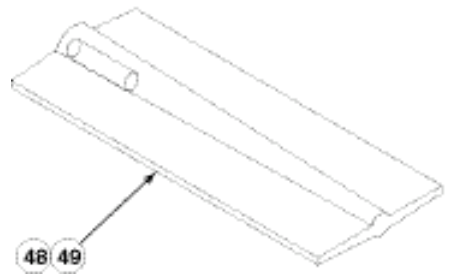

SECTION "C-C"
 (SECCION "C-C")

*See Page 46 for Slave Connection
 (*Vea la Página 46 para la Conexión Esclavada)

● Model 138-LRC 90° Parts List

Lista de Partes del Modelo 138-LRC 90°



See Page 25 for Information on How To Order Replacement Parts

Vea la Página 25 para información sobre como ordenar partes de repuesto

Recommended Spare Parts Highlighted In Gray

Partes de Repuesto Recomendadas se Resaltan en Gris

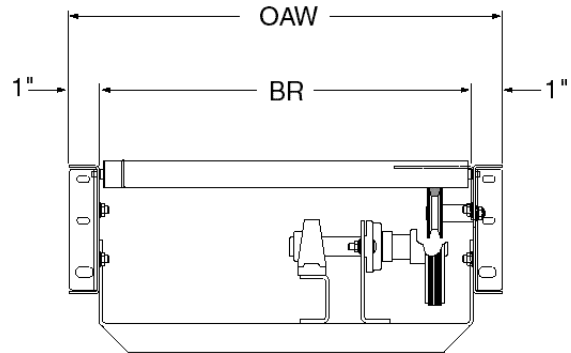

Ref. No.	Part No.	Description
1	—	Motor—Foot Mounted
—	030.2034	1/2 Hp—230/460 VAC—3 Ph.—60 Hz. — TEFC
2	—	4A Speed Reducer
—	R-00152-20R	RH—20:1 Ratio
—	R-00152-20L	LH—20:1 Ratio
3	028.1005	Sprocket—Reducer, 50B12 x 1 in. Bore
4	028.133	Sprocket—Drive Shaft, 50B14 x 1 in. Bore
5	020.104	Sheave—Motor, 3.00 in. O.D. x 5/8 in. Bore
6	020.120	Sheave—Reducer, 5.00 in. O.D. x 3/4 in. Bore
7	090.202	Shaft Key—3/16 in. Sq. x 1 in. Long
8	090.203	Shaft Key—1/4 in. Sq. x 1 in. Bore
9	—	V-Belt (Motor to Reducer)
—	066.105	4L270 (12 in. thru 15 in. OAW)
—	066.109	4L310 (18 in. thru 24 in. OAW)
10	029.101	#50 Riveted Roller Chain
11	029.201	Connector Link—#50 Roller Chain
12	—	Motor Base Assembly
—	B-15424	RH Reducer—12 in. thru 18 in. OAW (Specify)
—	B-15426	RH Reducer—24 in. OAW
—	B-15425	LH Reducer—12 in. thru 18 in. OAW (Specify)
—	B-15427	LH Reducer—24 in. OAW (Specify)
13	098.1505	Spacer—13/32 in. I.D. x 3/4 in. O.D. x 1-1/8 in. Long
14	098.1681	Spacer—13/32 in. I.D. x 1 in. O.D. x 2.304 in. Long
15	040.307	Take-Up Bolt—3/8-16 x 2-1/4 in. Long
16	041.300	Hex Jam Nut—Heavy—3/8-16
17	—	Inside V-Belt Guard
—	B-05275	14 in. Long—RH Reducer—12 in. thru 15 in. OAW
—	B-05120	16 in. Long—RH Reducer—18 in. thru 24 in. OAW
—	B-06580	14 in. Long—LH Reducer—12 in. thru 15 in. OAW
—	B-05558	16 in. Long—LH Reducer—18 in. thru 24 in. OAW
18	—	Outside V-Belt Guard
—	B-05274	14 in. Long—12 in. thru 15 in. OAW
—	B-05119	16 in. Long—18 in. thru 24 in. OAW
19	—	Chain Guard Back Plate
—	B-15109	RH Reducer
—	B-15110	LH Reducer
20	B-15112	Chain Guard Front Plate
21	041.919	Acorn Nut—3/8-16
22	—	Inside Channel
—	B-15981	12 in. thru 18 in. OAW
—	B-14830	24 in. OAW
23	—	Outside Channel
—	B-15982	12 in. thru 18 in. OAW (Specify)
—	B-14831	24 in. OAW
24	—	6-1/4 in. Tangent Channel
—	B-15983	12 in. thru 18 in. OAW
—	B-14862	24 in. OAW
25	B-14860	Coupling Angle
26	B-14756	Butt Coupling
27	—	V-Belt (Drive)
—	066.1315	B-120 (12 in. thru 18 in. OAW)
—	066.1325	B-144 (24 in. OAW)
28	B-05477	Threaded Section Spacer (Specify BR)
29	B-03102	Take-Up Bracket (Specify BR)
30	B-03092	Threaded Take-Up Rod (Specify Length)
31	B-03091	Sheave Take-Up Angle
32	041.201	Hex Jam Nut—1/2-13
33	024.1216	V-Idler Sheave—4 in. O.D. x 5/8 in. Bore
34	098.1565	Spacer-.687 I.D. x 1 in. O.D. x .25 Long
35	041.104	Hex Nut—5/8-11

Ref. No.	Part No.	Description
36	043.104	Flat Washer—5/8 in. I.D.
37	043.204	Split Lockwasher—5/8 in. I.D.
38	040.5031	Hex Head Cap Screw—5/8-11 x 2-3/4 in. Long
39	B-03195	Fixed Idler Bracket (Specify BR)
40	024.12431	Sheave—2-1/2 in. O.D. x 3/8 in. Bore with Spacer
41	043.101	Flat Washer 5/16 in. I.D.
42	049.5285	Flange Locknut—3/8 in.-16
43	—	One Groove Roller
—	B-06533	1-3/8 in. Dia. (12 in. thru 18 in. OAW) (Specify BR)
—	B-06535-176	1.9 in. Dia. Roller (24 in. OAW)
44	B-06534	Two Groove Roller (12 in. thru 18 in. OAW) (Specify)
45	—	Tread Roller
—	B-03935	1-3/8 in. Dia. (12 in. thru 18 in. OAW) (Specify BR)
—	G-00486-176	1.9 in. Dia. Roller (24 in. OAW)
46	—	O-Ring—1/8 in. Dia.
—	090.2548	12 in. thru 18 in. OAW
—	090.255	24 in. OAW
47	B-09799	End Guard (Specify OAW)
48	092.159	V-Belt Shield (24 in. OAW Only)
49	049.317	Self-Tapping Hex Screw—1/4-20 x 3/4 in. Lg. 24" OAW
50	—	LS Type Pivot Plate—1-1/8 in. Flange
—	G-00248	4 in. High
—	G-00249	1-7/8 in. High
51	—	Floor Support Frame
—	B-00914	6 in. High (Specify OAW)
—	B-12777	7 in. High (Specify OAW)
—	B-12778	8 in. High (Specify OAW)
—	B-00915	9 in. High (Specify OAW)
—	B-00916	11-1/2 in. High (Specify OAW)
—	B-00917	14-1/2 in. High (Specify OAW)
—	B-02098	18-1/2 in. High (Specify OAW)
—	B-00919	22-1/2 in. High (Specify OAW)
—	B-00921	32-1/2 in. High (Specify OAW)
—	B-00923	44-1/2 in. High (Specify OAW)
—	B-00925	56-1/2 in. High (Specify OAW)
—	B-02107	68-1/2 in. High (Specify OAW)
—	B-02109	78-1/2 in. High (Specify OAW)
—	B-02111	90-1/2 in. High (Specify OAW)
52	B-00909	Center Support Leg (Specify Length)
53	B-00911	Adjustable Foot Assembly (Specify Length)

TAPERED ROLLER CURVE		
54	—	Inside Channel
—	B-15343	12 in. thru 18 in. OAW
—	B-15345	24 in. OAW
55	—	Outside Channel
—	B-15344	12 in. thru 18 in. OAW (Specify)
—	B-15346	24 in. OAW
56	B-14861	6-1/4 in. Long Tangent Channel
57	G-02680	1-3/8 in. Dia. Roller (Specify BR)
58	B-15156	1-3/8 in. Dia. Single Groove Roller (Specify BR)
59	B-15157	1-3/8 in. Dia. Single Groove Roller (Specify BR)
60	B-15371	1-3/8 in. Tapered Roller (Specify BR)
61	—	Spacer Rod - 5/16 in. Threaded Rod
—	044.1142	12 in. OAW
—	044.1144	15 in. OAW
—	044.1146	18 in. OAW
—	044.1148	24 in. OAW

● Model 138-LRC 60° Parts Drawing

Dibujo de Partes del Modelo 138-LRC 60°

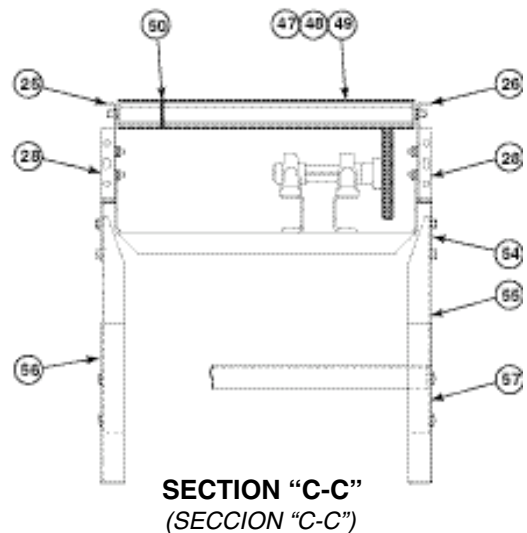
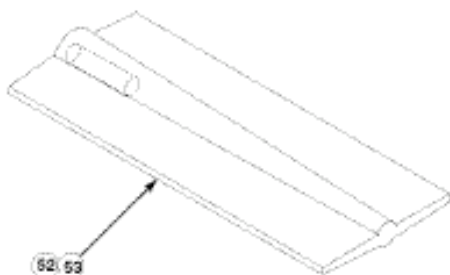
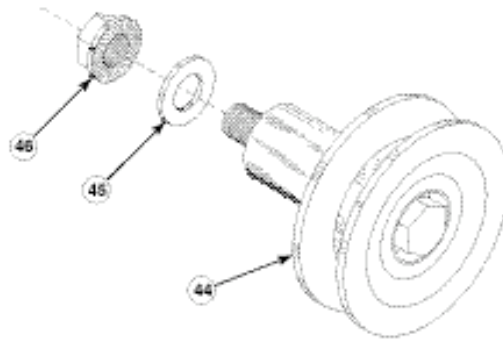
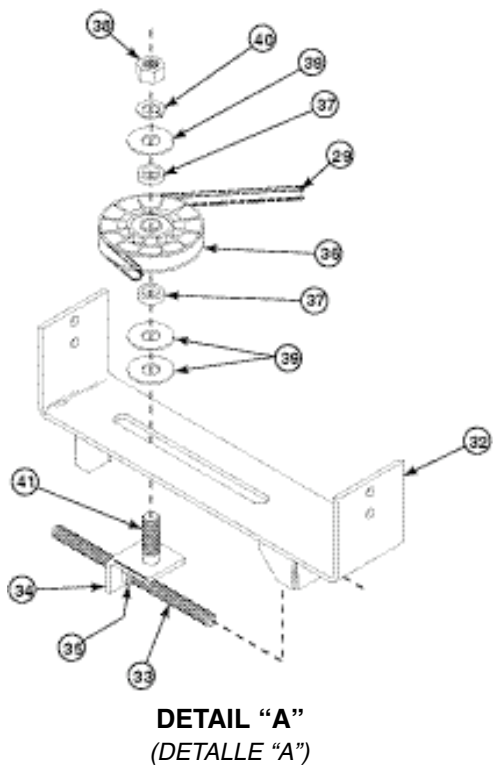
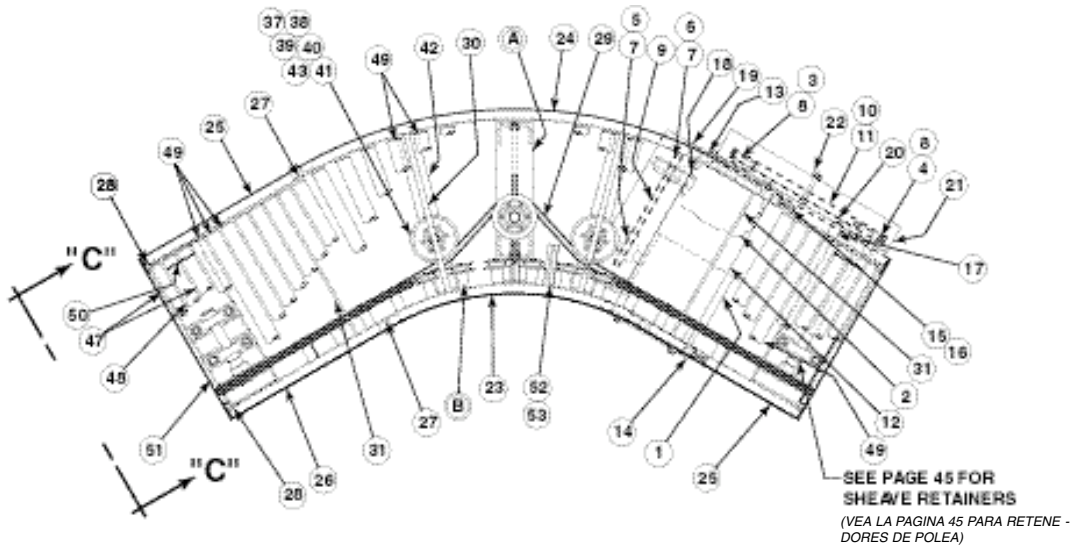

*See Page 46 for Slave Connection
(*Vea la Página 46 para la Conexión Esclavada)

● Model 138-LRC 60° Parts List

Lista de Partes del Modelo 138-LRC 60°



See Page 25 for Information on How To
Order Replacement Parts
Vea la Página 25 para información sobre como
ordenar partes de repuesto

Recommended Spare Parts Highlighted In Gray

Partes de Repuesto Recomendadas
se Resaltan en Gris

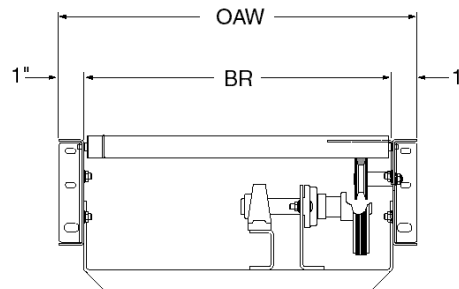

Ref. No.	Part No.	Description
1	—	Motor—Foot Mounted
—	030.2034	1/2 Hp—230/460 VAC—3 Ph.—60 Hz. — TEFC
2	—	4A Speed Reducer
—	R-00152-20R	RH—20:1 Ratio
—	R-00152-20L	LH—20:1 Ratio
3	028.1005	Sprocket—Reducer, 50B12 x 1 in. Bore
4	028.133	Sprocket—Drive Shaft, 50B14 x 1 in. Bore
5	020.104	Sheave—Motor, 3.00 in. O.D. x 5/8 in. Bore
6	020.120	Sheave—Reducer, 5.00 in. O.D. x 3/4 in. Bore
7	090.202	Shaft Key—3/16 in. Sq. x 1 in. Long
8	090.203	Shaft Key—1/4 in. Sq. x 1 in. Bore
9	—	V-Belt (Motor to Reducer)
—	066.105	4L270 (12 in. thru 15 in. OAW)
—	066.109	4L310 (18 in. thru 24 in. OAW)
10	029.101	#50 Riveted Roller Chain
11	029.201	Connector Link—#50 Roller Chain
12	—	Motor Base Assembly
—	B-05537	RH Reducer—12 in. thru 15 in. OAW (Specify)
—	B-05536-018	RH Reducer—18 in. OAW
—	B-05534-024	RH Reducer—24 in. OAW
—	B-08543	LH Reducer—12 in. thru 15 in. OAW (Specify)
—	B-08544-018	LH Reducer—18 in. OAW
—	B-08545-024	LH Reducer—24 in. OAW
13	B-15462	Motor Base Support Angle—LH
14	B-15463	Motor Base Support Angle—RH
15	040.307	Take-Up Bolt—3/8-16 x 2-1/4 in. Long
16	041.300	Hex Jam Nut—Heavy—3/8-16
17	098.1505	Spacer—13/32 in. I.D. x 3/4 in. O.D. x 1-1/8 in. Long
18	—	Inside V-Belt Guard
—	B-05275	14 in. Long—RH Reducer—12 in. thru 15 in. OAW
—	B-05120	16 in. Long—RH Reducer—18 in. thru 24 in. OAW
—	B-06580	14 in. Long—LH Reducer—12 in. thru 15 in. OAW
—	B-05558	16 in. Long—LH Reducer—18 in. thru 24 in. OAW
19	—	Outside V-Belt Guard
—	B-05274	14 in. Long—12 in. thru 15 in. OAW
—	B-05119	16 in. Long—18 in. thru 24 in. OAW
20	—	Chain Guard Back Plate
—	B-15109	RH Reducer
—	B-15110	LH Reducer
21	B-15112	Chain Guard Front Plate
22	041.919	Acorn Nut—3/8-16
23	—	Inside Channel
—	B-15979	12 in. thru 18 in. OAW
—	B-14836	24 in. OAW
24	—	Outside Channel
—	B-15980	12 in. thru 18 in. OAW (Specify)
—	B-14837	24 in. OAW
25	—	18 in. Tangent Channel—LH
—	B-15984-18L	12 in. thru 18 in. OAW
—	B-14866-18L	24 in. OAW
26	—	18 in. Tangent Channel—RH
—	B-15984-18R	12 in. thru 18 in. OAW
—	B-14866-18R	24 in. OAW
27	B-14860	Coupling Angle
28	B-14756	Butt Coupling
29	—	V-Belt (Drive)
—	066.607	B-136 (12 in. thru 18 in. OAW)
—	066.1326	B-158 (24 in. OAW)
30	B-05477	Threaded Section Spacer—Curve Portion (Specify BR)
31	—	Threaded Section Spacer—Straight Portion
—	040.105	10 in. BR (Bolt)
—	040.106	13 in. BR (Bolt)
—	040.107	16 in. BR (Bolt)
—	B-05477-022	22 in. BR (Pipe)
32	B-03102	Take-Up Bracket (Specify BR)

Ref. No.	Part No.	Description
33	B-03092	Threaded Take-Up Rod (Specify Length)
34	B-03091	Sheave Take-Up Angle
35	041.201	Hex Jam Nut—1/2-13
36	024.1216	V-Idler Sheave—4 in. O.D. x 5/8 in. Bore
37	098.1565	Spacer—.687 I.D. x 1 in. O.D. x .25 Long
38	041.104	Hex Nut—5/8-11
39	043.104	Flat Washer—5/8 in. I.D.
40	043.204	Split Lockwasher—5/8 in. I.D.
41	040.5031	Hex Head Cap Screw—5/8-11 x 2-3/4 in. Long
42	B-03195	Fixed Idler Bracket (Specify BR)
43	024.1226	Flat Idler Sheave 5-1/2 in. O.D. x 5/8 in. Bore
44	024.12431	Sheave—2-1/2 in. O.D. x 3/8 in. Bore with Spacer
45	043.101	Flat Washer 5/16 in. I.D.
46	049.5285	Flange Locknut—3/8 in.-16
47	—	One Groove Roller
—	B-06533	1-3/8 in. Dia. (12 in. thru 18 in. OAW) (Specify BR)
—	B-06535-176	1.9 in. Dia. (24 in. OAW)
48	B-06534	Two Groove Roller (12 in. thru 18 in. OAW) (Specify BR)
49	—	Tread Roller
—	B-03935	1-3/8 in. Dia. (12 in. thru 18 in. OAW) (Specify BR)
—	B-01982-176	1.9 in. Tapered (24 in. OAW) (Straight Portion)
—	G-00486-176	1.9 in. Tapered (24 in. OAW) (Curve Portion)
50	—	O-Ring—1/8 in. Dia.
—	090.2548	12 in. thru 18 in. OAW
—	090.255	24 in. OAW
51	B-09799	End Guard (Specify OAW)
52	092.159	V-Belt Shield (24 in. OAW Only)
53	049.317	Self-Tapping Hex Screw—1/4-20 x 3/4 in. Long
54	—	LS Type Pivot Plate—1-1/8 in. Flange
—	B-00248	4 in. High
—	B-00249	1-7/8 in. High
55	—	Floor Support Frame
—	B-00914	6 in. High (Specify OAW)
—	B-12777	7 in. High (Specify OAW)
—	B-12778	8 in. High (Specify OAW)
—	B-00915	9 in. High (Specify OAW)
—	B-00916	11-1/2 in. High (Specify OAW)
—	B-00917	14-1/2 in. High (Specify OAW)
—	B-02098	18-1/2 in. High (Specify OAW)
—	B-00919	22-1/2 in. High (Specify OAW)
—	B-00921	32-1/2 in. High (Specify OAW)
—	B-00923	44-1/2 in. High (Specify OAW)
—	B-00925	56-1/2 in. High (Specify OAW)
—	B-02107	68-1/2 in. High (Specify OAW)
—	B-02109	78-1/2 in. High (Specify OAW)
—	B-02111	90-1/2 in. High (Specify OAW)
56	B-00909	Center Support Leg (Specify Length)
57	B-00911	Adjustable Foot Assembly (Specify Length)

TAPERED ROLLER CURVE		
58	—	Inside Channel
—	B-15339	12 in. thru 18 in. OAW
—	B-15341	24 in. OAW
59	—	Outside Channel
—	B-15340	12 in. thru 18 in. OAW (Specify)
—	B-15342	24 in. OAW
60	B-14865-18L	18 in. Long Tangent Channel - LH
61	B-14865-18R	18 in. Long Tangent Channel - RH
62	G-02680	1-3/8 in. Dia. Roller (Specify BR)
63	B-15156	1-3/8 in. Dia. Single Groove Roller (Specify BR)
64	B-15157	1-3/8 in. Dia. Single Groove Roller (Specify BR)
65	B-15371	1-3/8 in. Tapered Roller (Specify BR)
66	—	Spacer Rod - 5/16 in. Threaded Rod
—	044.1142	12 in. OAW
—	044.1144	15 in. OAW
—	044.1146	18 in. OAW
—	044.1148	24 in. OAW

● Model 138-LRC 45° Parts Drawing
Dibujo de Partes del Modelo 138-LRC 45°

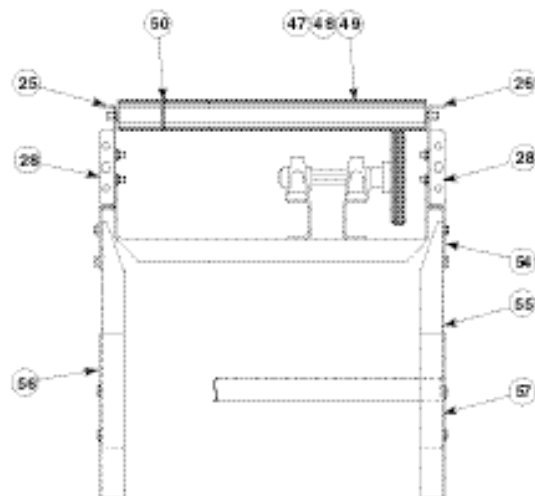
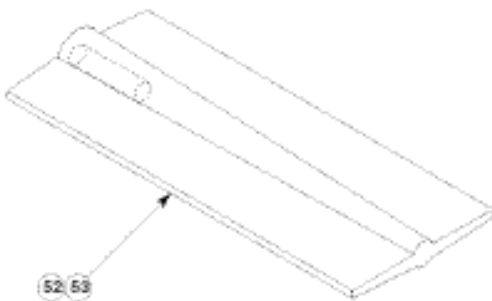
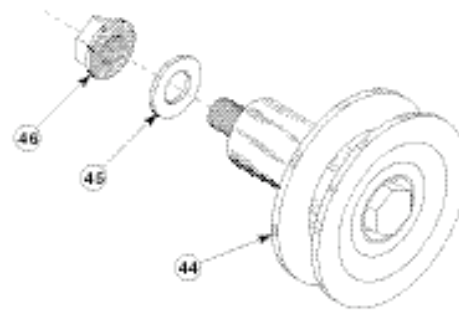
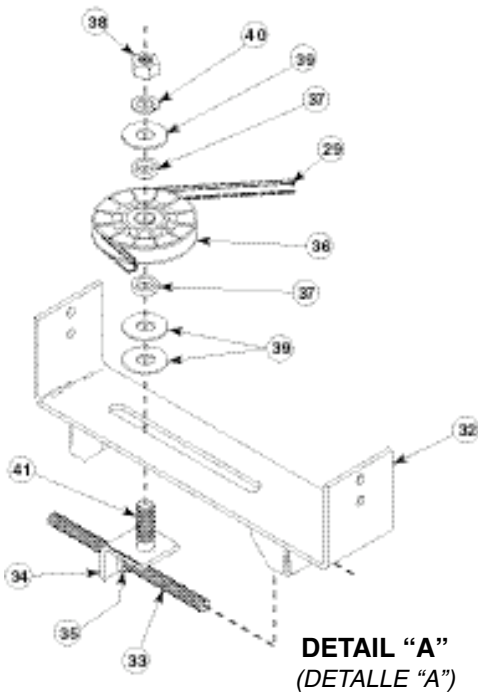
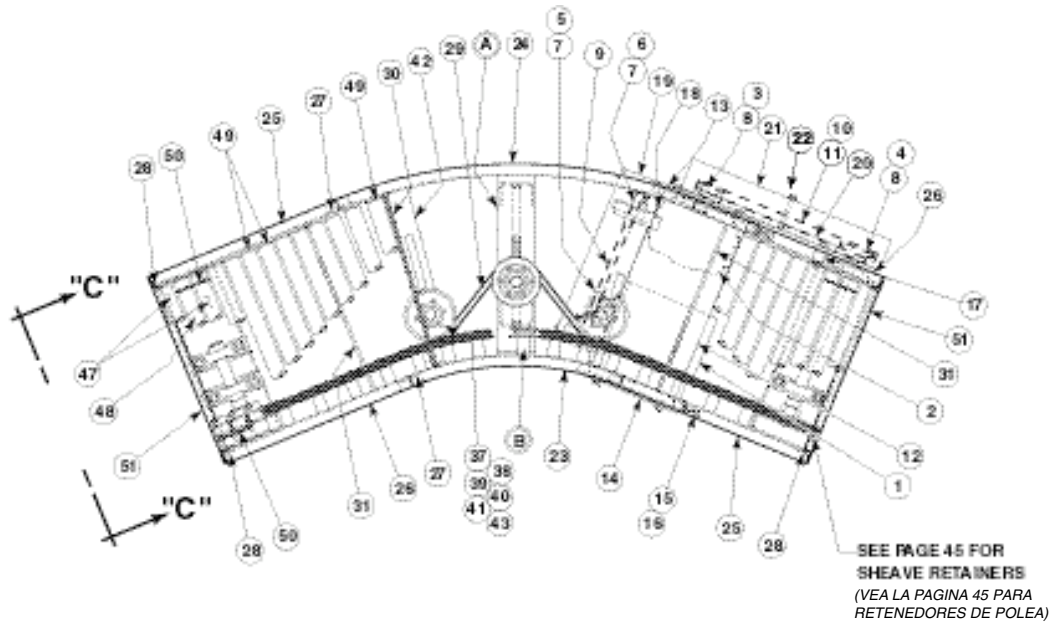

*See Page 46 for Slave Connection
 (*Vea la Página 46 para la Conexión Esclavada)

● Model 138-LRC 45° Parts List

Lista de Partes del Modelo 138-LRC 45°



See Page 25 for Information on How To Order Replacement Parts

Veá la Página 25 para información sobre como ordenar partes de repuesto

Recommended Spare Parts Highlighted In Gray

Partes de Repuesto Recomendadas se Resaltan en Gris

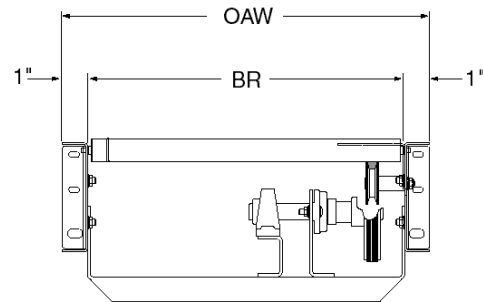

Ref. No.	Part No.	Description
1	—	Motor—Foot Mounted
—	030.2034	1/2 Hp—230/460 VAC—3 Ph.—60 Hz. — TEFC
2	—	4A Speed Reducer
—	R-00152-20R	RH—20:1 Ratio
—	R-00152-20L	LH—20:1 Ratio
3	028.1005	Sprocket—Reducer, 50B12 x 1 in. Bore
4	028.133	Sprocket—Drive Shaft, 50B14 x 1 in. Bore
5	020.104	Sheave—Motor, 3.00 in. O.D. x 5/8 in. Bore
6	020.120	Sheave—Reducer, 5.00 in. O.D. x 3/4 in. Bore
7	090.202	Shaft Key—3/16 in. Sq. x 1 in. Long
8	090.203	Shaft Key—1/4 in. Sq. x 1 in. Bore
9	—	V-Belt (Motor to Reducer)
—	066.105	4L270 (12 in. thru 15 in. OAW)
—	066.109	4L310 (18 in. thru 24 in. OAW)
10	029.101	#50 Riveted Roller Chain
11	029.201	Connector Link—#50 Roller Chain
12	—	Motor Base Assembly
—	B-05537	RH Reducer—12 in. thru 15 in. OAW (Specify)
—	B-05536-018	RH Reducer—18 in. OAW
—	B-05534-024	RH Reducer—24 in. OAW
—	B-08543	LH Reducer—12 in. thru 15 in. OAW (Specify)
—	B-08544-018	LH Reducer—18 in. OAW
—	B-08545-024	LH Reducer—24 in. OAW
13	B-15462	Motor Base Support Angle —LH
14	B-15463	Motor Base Support Angle —RH
15	040.307	Take-Up Bolt—3/8-16 x 2-1/4 in. Long
16	041.300	Hex Jam Nut—Heavy—3/8-16
17	098.1505	Spacer—13/32 in. I.D. x 3/4 in. O.D. x 1-1/8 Long
18	—	Inside V-Belt Guard
—	B-05275	14 in. Long—RH Reducer—13 in. BR
—	B-05120	16 in. Long—RH Reducer—15 in. thru 39 in. BR
—	B-06580	14 in. Long—LH Reducer—13 in. BR
—	B-05558	16 in. Long—LH Reducer—15 in. thru 39 in. BR
19	—	Outside V-Belt Guard
—	B-05274	14 in. Long—12 in. thru 15 in. OAW
—	B-05119	16 in. Long—18 in. thru 24 in. OAW
20	—	Chain Guard Back Plate
—	B-15109	RH Reducer
—	B-15110	LH Reducer
21	B-15112	Chain Guard Front Plate
22	041.919	Acorn Nut—3/8-16
23	—	Inside Channel
—	B-15977	12 in. thru 18 in. OAW
—	B-14832	24 in. OAW
24	—	Outside Channel
—	B-15978	12 in. thru 18 in. OAW (Specify)
—	B-14833	24 in. OAW
25	—	18 in. Tangent Channel—LH
—	B-15984-18L	12 in. thru 18 in. OAW
—	B-14866-18L	24 in. OAW
26	—	18 in. Tangent Channel—RH
—	B-15984-18R	12 in. thru 18 in. OAW
—	B-14866-18R	24 in. OAW
27	B-14860	Coupling Angle
28	B-14756	Butt Coupling
29	—	V-Belt (Drive)
—	066.614	B-124 (12 in. thru 18 in. OAW)
—	066.607	B-136 (24 in. OAW)
30	B-05477	Threaded Section Spacer—Curve Portion (Specify BR)
31	—	Threaded Section Spacer—Strait Portion
—	040.105	10 in. BR (Bolt)
—	040.106	13 in. BR (Bolt)
—	040.107	16 in. BR (Bolt)
—	B-05477-022	22 in. BR (Pipe)
32	B-03102	Take-Up Bracket (Specify BR)

Ref. No.	Part No.	Description
33	B-03092	Threaded Take-Up Rod (Specify Length)
34	B-03091	Sheave Take-Up Angle
35	041.201	Hex Jam Nut—1/2-13
36	024.1216	V-Idler Sheave—4 in. O.D. x 5/8 in. Bore
37	098.1565	Spacer—.687 I.D. x 1 in. O.D. x .25 Long
38	041.104	Hex Nut—5/8-11
39	043.104	Flat Washer—5/8 in. I.D.
40	043.204	Split Lockwasher—5/8 in. I.D.
41	040.5031	Hex Head Cap Screw—5/8-11 x 2-3/4 in. Long
42	B-03195	Fixed Idler Bracket (Specify BR)
43	024.1226	Flat Idler Sheave 5-1/2 in. O.D. x 5/8 in. Bore
44	024.12431	Sheave—2-1/2 in. O.D. x 3/8 in. Bore with Spacer
45	043.101	Flat Washer 5/16 in. I.D.
46	049.5285	Flange Locknut - 3/8 in. - 16
47	—	One Groove Roller
—	B-06533	1-3/8 in. Dia. (12 in thru 18 in OAW)(Specify BR)
—	B-06535-176	1.9 in. Dia. (24 in. OAW)
48	B-06534	Two Groove Roller (12 in. thru 18 in. OAW) (Specify BR)
49	—	Tread Roller
—	B-03935	1-3/8 in. Dia. (12 in. thru 18 in. OAW) (Specify BR)
—	B-01982-176	1.9 in. Tapered (24 in. OAW) (Straight Portion)
—	G-00486-176	1.9 in. Tapered (24 in. OAW) (Curve Portion)
50	—	O-Ring—1/8 in. Dia.
—	090.2548	12 in. thru 18 in. OAW
—	090.255	24 in. OAW
51	B-09799	End Guard (Specify OAW)
52	092.159	V-Belt Shield
53	049.317	Self-Tapping Hex Screw—1/4-20 x 3/4 in. Long
54	—	LS Type Pivot Plate—1-1/8 in. Flange
—	G-00248	4 in. High
—	G-00249	1-7/8 in. High
55	—	Floor Support Frame
—	B-00914	6 in. High (Specify OAW)
—	B-12777	7 in. High (Specify OAW)
—	B-12778	8 in. High (Specify OAW)
—	B-00915	9 in. High (Specify OAW)
—	B-00916	11-1/2 in. High (Specify OAW)
—	B-00917	14-1/2 in. High (Specify OAW)
—	B-02098	18-1/2 in. High (Specify OAW)
—	B-00919	22-1/2 in. High (Specify OAW)
—	B-00921	32-1/2 in. High (Specify OAW)
—	B-00923	44-1/2 in. High (Specify OAW)
—	B-00925	56-1/2 in. High (Specify OAW)
—	B-02107	68-1/2 in. High (Specify OAW)
—	B-02109	78-1/2 in. High (Specify OAW)
—	B-02111	90-1/2 in. High (Specify OAW)
56	B-00909	Center Support Leg (Specify Length)
57	B-00911	Adjustable Foot Assembly (Specify Length)

TAPERED ROLLER CURVE

58	—	Inside Channel
—	B-15335	12 in. thru 18 in. OAW
—	B-15337	24 in. OAW
59	—	Outside Channel
—	B-15336	12 in. thru 18 in. OAW (Specify)
—	B-15338	24 in. OAW
60	B-14865-18L	18 in. Long Tangent Channel - LH
61	B-14865-18R	18 in. Long Tangent Channel - RH
62	G-02680	1-3/8 in. Dia. Roller (Specify BR)
63	B-15156	1-3/8 in. Dia. Single Groove Roller (Specify BR)
64	B-15157	1-3/8 in. Dia. Single Groove Roller (Specify BR)
65	B-15371	1-3/8 in. Tapered Roller (Specify BR)
66	—	Spacer Rod - 5/16 in. Threaded Rod
—	044.1142	12 in. OAW
—	044.1144	15 in. OAW
—	044.1146	18 in. OAW
—	044.1148	24 in. OAW

● Model 138-LRC 30° Parts Drawing
Dibujo de Partes del Modelo 138-LRC 30°

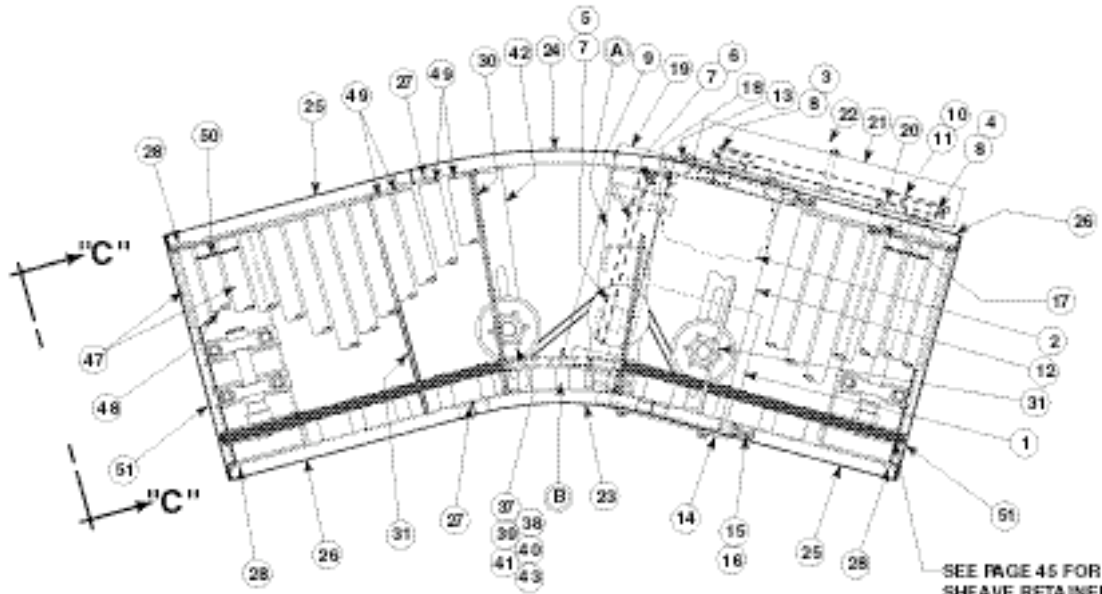

SEE PAGE 45 FOR
 SHEAVE RETAINERS
 (VEA LA PAGINA 45 PARA
 RETENEDORES DE POLEAS)

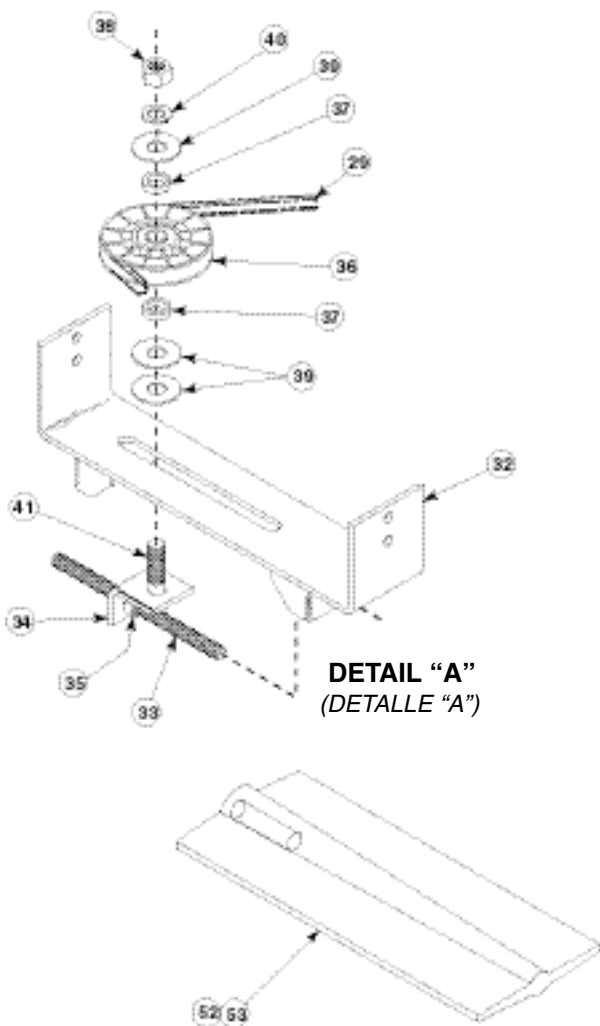

DETAIL "A"
 (DETALLE "A")

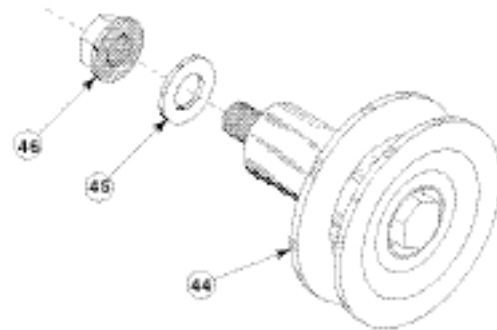

DETAIL "B"
 (DETALLE "B")

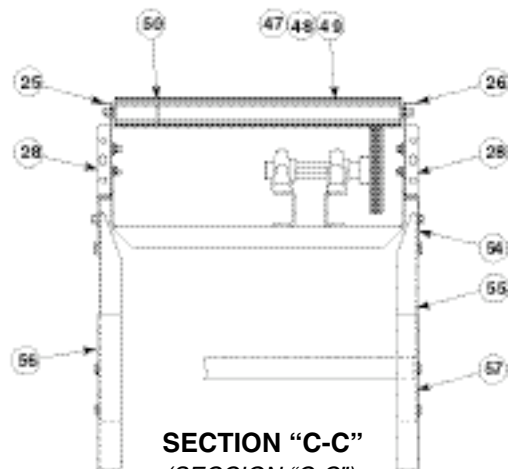

SECTION "C-C"
 (SECCION "C-C")

*See Page 46 for Slave Connection
 (*Vea la Página 46 para la Conexión Esclavada)

● Model 138-LRC 30° Parts List

Lista de Partes del Modelo 138-LRC 30°



See Page 25 for Information on How To Order Replacement Parts

Ve la Página 25 para información sobre como ordenar partes de repuesto

Recommended Spare Parts Highlighted In Gray

Partes de Repuesto Recomendadas se Resaltan en Gris

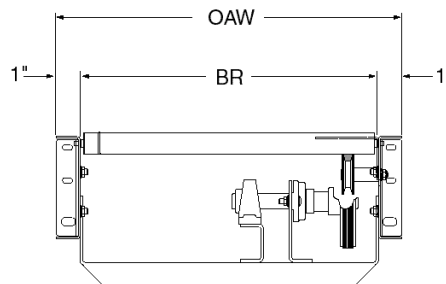

Ref. No.	Part No.	Description
1	—	Motor—Foot Mounted
—	030.2034	1/2 Hp—230/460 VAC—3 Ph.—60 Hz. — TEFC
2	—	4A Speed Reducer
—	R-00152-20R	RH—20:1 Ratio
—	R-00152-20L	LH—20:1 Ratio
3	028.1005	Sprocket—Reducer, 50B12 x 1 in. Bore
4	028.133	Sprocket—Drive Shaft, 50B14 x 1 in. Bore
5	020.104	Sheave—Motor, 3.00 in. O.D. x 5/8 in. Bore
6	020.120	Sheave—Reducer, 5.00 in. O.D. x 3/4 in. Bore
7	090.202	Shaft Key—3/16 in. Sq. x 1 in. Long
8	090.203	Shaft Key—1/4 in. Sq. x 1 in. Bore
9	—	V-Belt (Motor to Reducer)
—	066.105	4L270 (13 in. BR)
—	066.109	4L310 (15 in. thru 39 in. BR)
10	029.101	#50 Riveted Roller Chain
11	029.201	Connector Link—#50 Roller Chain
12	—	Motor Base Assembly
—	B-05537	RH Reducer—12 in. thru 15 in. OAW (Specify)
—	B-05536-018	RH Reducer—18 in. OAW
—	B-05534-024	RH Reducer—24 in. OAW
—	B-08543	LH Reducer—12 in. thru 15 in. OAW
—	B-08544-018	LH Reducer—18 in. OAW
—	B-08545-024	LH Reducer—24 in. OAW
13	B-15462	Motor Base Support Angle—LH
14	B-15263	Motor Base Support Angle—RH
15	040.307	Take-Up Bolt—3/8-16 x 2-1/4 in. Long
16	041.300	Hex Jam Nut—Heavy—3/8-16
17	098.1505	Spacer—13/32 in. I.D. x 3/4 in. O.D. x 1-1/8 in. Long
18	—	Inside V-Belt Guard
—	B-05275	14 in. Long—RH Reducer—12 in. thru 15 in. OAW
—	B-05120	16 in. Long—RH Reducer—18 in. thru 24 in. OAW
—	B-06580	14 in. Long—LH Reducer—12 in. thru 15 in. OAW
—	B-05558	16 in. Long—LH Reducer—18 in. thru 24 in. OAW
19	—	Outside V-Belt Guard
—	B-05274	14 in. Long—12 in. thru 15 in. OAW
—	B-05119	16 in. Long—18 in. thru 24 in. OAW
20	—	Chain Guard Back Plate
—	B-15109	RH Reducer
—	B-15110	LH Reducer
21	B-15112	Chain Guard Front Plate
22	041.919	Acorn Nut—3/8-16
23	—	Inside Channel
—	B-15975	12 in. thru 18 in. OAW
—	B-14834	24 in. OAW
24	—	Outside Channel
—	B-15976	12 in. thru 18 in. OAW
—	B-14835	24 in. OAW
25	—	18 in. Tangent Channel—LH
—	B-15984-18L	12 in. thru 18 in. OAW
—	B-14866-18L	24 in. OAW
26	—	18 in. Tangent Channel—RH
—	B-15984-18R	12 in. thru 18 in. OAW
—	B-14834-18R	24 in. OAW
27	B-14860	Coupling Angle
28	B-14756	Butt Coupling
29	—	V-Belt (Drive)
—	066.13065	B-108 (12 in. thru 18 in. OAW)
—	066.1308	B-116 (24 in. OAW)
30	B-05477	Threaded Section Spacer—Curve Portion (Specify BR)
31	—	Threaded Section Spacer—Strait Portion
—	040.105	10 in. BR (Bolt)
—	040.106	13 in. BR (Bolt)
—	040.107	16 in. BR (Bolt)
—	B-05477-022	22 in. BR (Pipe)
32	B-03102	Take-Up Bracket (Specify BR)

Ref. No.	Part No.	Description
33	B-03092	Threaded Take-Up Rod (Specify Length)
34	B-03091	Sheave Take-Up Angle
35	041.201	Hex Jam Nut—1/2-13
36	024.1216	V-Idler Sheave—4 in. O.D. x 5/8 in. Bore
37	098.1565	Spacer—.687 I.D. x 1 in. O.D. x .25 Long
38	041.104	Hex Nut—5/8-11
39	043.104	Flat Washer—5/8 in. I.D.
40	043.204	Split Lockwasher—5/8 in. I.D.
41	040.5031	Hex Head Cap Screw—5/8-11 x 2-3/4 in. Long
42	B-03195	Fixed Idler Bracket (Specify BR)
43	024.1226	Flat Idler Sheave 5-1/2 in. O.D. x 5/8 in. Bore
44	024.12431	Sheave—2-1/2 in. O.D. x 3/8 in. Bore with Spacer
45	043.101	Flat Washer 5/16 in. I.D.
46	049.5285	Flange Locknut - 3/8 in. - 16
47	—	One Groove Roller
—	B-06533	1-3/8 in. Dia. (12 in thru 18 in OAW)(Specify BR)
—	B-06535-176	1.9 in. Dia. (24 in. OAW)
48	B-06534	Two Groove Roller (12 in. thru 18 in. OAW) (Specify BR)
49	—	Tread Roller
—	B-03935	1-3/8 in. Dia. (12 in. thru 18 in. OAW) (Specify BR)
—	B-01982-176	1.9 in. Tapered (24 in. OAW) (Straight Portion)
—	G-00486-176	1.9 in. Tapered (24 in. OAW) (Curve Portion)
50	—	O-Ring—1/8 in. Dia.
—	090.2548	12 in. thru 18 in. OAW
—	090.255	24 in. OAW
51	B-09799	End Guard (Specify OAW)
52	092.159	V-Belt Shield
53	049.317	Self-Tapping Hex Screw—1/4-20 x 3/4 in. Long
54	—	LS Type Pivot Plate—1-1/8 in. Flange
—	G-00248	4 in. High
—	G-00249	1-7/8 in. High
55	—	Floor Support Frame
—	B-00914	6 in. High (Specify OAW)
—	B-12777	7 in. High (Specify OAW)
—	B-12778	8 in. High (Specify OAW)
—	B-00915	9 in. High (Specify OAW)
—	B-00916	11-1/2 in. High (Specify OAW)
—	B-00917	14-1/2 in. High (Specify OAW)
—	B-02098	18-1/2 in. High (Specify OAW)
—	B-00919	22-1/2 in. High (Specify OAW)
—	B-00921	32-1/2 in. High (Specify OAW)
—	B-00923	44-1/2 in. High (Specify OAW)
—	B-00925	56-1/2 in. High (Specify OAW)
—	B-02107	68-1/2 in. High (Specify OAW)
—	B-02109	78-1/2 in. High (Specify OAW)
—	B-02111	90-1/2 in. High (Specify OAW)
56	B-00909	Center Support Leg (Specify Length)
57	B-00911	Adjustable Foot Assembly (Specify Length)

TAPERED ROLLER CURVE		
58	—	Inside Channel
—	B-15331	12 in. thru 18 in. OAW
—	B-15333	24 in. OAW
59	—	Outside Channel
—	B-15332	12 in. thru 18 in. OAW (Specify)
—	B-15334	24 in. OAW
60	B-14865-18L	18 in. Long Tangent Channel - LH
61	B-14865-18R	18 in. Long Tangent Channel - RH
62	G-02680	1-3/8 in. Dia. Roller (Specify BR)
63	B-15156	1-3/8 in. Dia. Single Groove Roller (Specify BR)
64	B-15157	1-3/8 in. Dia. Single Groove Roller (Specify BR)
65	B-15371	1-3/8 in. Tapered Roller (Specify BR)
66	—	Spacer Rod - 5/16 in. Threaded Rod
—	044.1142	12 in. OAW
—	044.1144	15 in. OAW
—	044.1146	18 in. OAW
—	044.1148	24 in. OAW

● Model 138-LRS 45° Parts Drawing

Dibujo de Partes del Modelo 138-LRS 45°

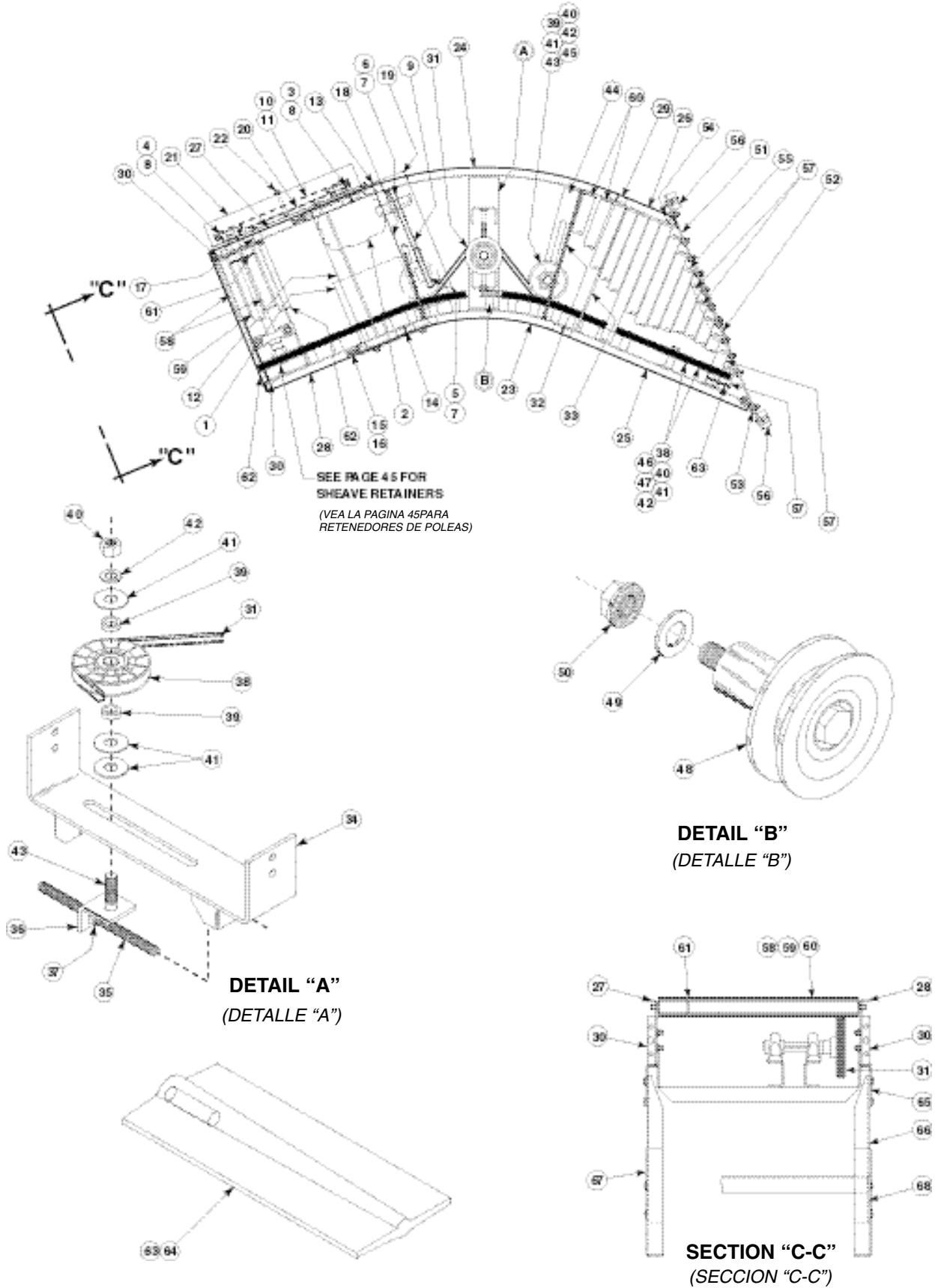

*See Page 46 for Slave Connection
(*Vea la Página 46 para la Conexión Esclavada)

● Model 138-LRS 45° Parts List

Lista de Partes del Modelo 138-LRS 45°



See Page 25 for Information on How To Order Replacement Parts

Veá la Página 25 para información sobre como ordenar partes de repuesto

Recommended Spare Parts Highlighted In Gray

Partes de Repuesto Recomendadas se Resaltan en Gris

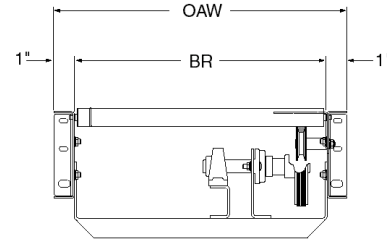

Ref. No.	Part No.	Description
1	030.2034	Motor—Foot Mounted 1/2 Hp—230/460 VAC—3 Ph.—60 Hz. — TEFC
2	—	4A Speed Reducer
—	R-00152-20R	RH—20:1 Ratio
—	R-00152-20L	LH—20:1 Ratio
3	028.1005	Sprocket—Reducer, 50B12 x 1 in. Bore
4	028.133	Sprocket—Drive Shaft, 50B14 x 1 in. Bore
5	020.104	Sheave—Motor, 3.00 in. O.D. x 5/8 in. Bore
6	020.120	Sheave—Reducer, 5.00 in. O.D. x 3/4 in. Bore
7	090.202	Shaft Key—3/16 in. Sq. x 1 in. Long
8	090.203	Shaft Key—1/4 in. Sq. x 1 in. Bore
9	—	V-Belt (Motor to Reducer)
—	066.105	4L270 (13 in. BR)
—	066.109	4L310 (15 in. thru 39 in. BR)
10	029.101	#50 Riveted Roller Chain
11	029.201	Connector Link—#50 Roller Chain
12	—	Motor Base Assembly
—	B-05537	RH Reducer—12 in. thru 15 in. OAW (Specify)
—	B-05536-018	RH Reducer—18 OAW
—	B-05534-024	RH Reducer—24 OAW
—	B-08543	LH Reducer—12 in. thru 15 in. OAW (Specify)
—	B-08544-018	LH Reducer—18 in. OAW
—	B-08545-024	LH Reducer—24 in. OAW
13	B-15462	Motor Base Support Angle—LH
14	B-15463	Motor Base Support Angle—RH
15	040.307	Take-Up Bolt—3/8-16 x 2-1/4 in. Long
16	041.300	Hex Jam Nut—Heavy—3/8-16
17	098.1505	Spacer 13/32 in. I.D. x 3/4 in. O.D. x 1-1/8 Long
18	—	Inside V-Belt Guard
—	B-05275	14 in. Long—RH Reducer—12 in. thru 15 in. OAW
—	B-05120	16 in. Long—RH Reducer—18 in. thru 24 in. OAW
—	B-06580	14 in. Long—LH Reducer—12 in. thru 15 in. OAW
—	B-05558	16 in. Long—LH Reducer—18 in. thru 24 in. OAW
19	—	Outside V-Belt Guard
—	B-05274	14 in. Long—12 in. thru 15 in. OAW
—	B-05119	16 in. Long—18 in. thru 24 in. OAW
20	—	Chain Guard Back Plate
—	B-15109	RH Reducer
—	B-15110	LH Reducer
21	B-15112	Chain Guard Front Plate
22	041.919	Acorn Nut—3/8-16
23	—	Inside Channel
—	B-15977	12 in. thru 18 in. OAW
—	B-14832	24 in. OAW
24	—	Outside Channel
—	B-15978	12 in. thru 18 in. OAW
—	B-14833	24 in. OAW
25	—	Long Straight Channel
—	B-15990	12 in. thru 18 in. OAW
—	B-14849	24 in. OAW
26	—	Short Straight Channel
—	B-15989	RH Spur—12 in. thru 18 in. OAW
—	B-14848	RH Spur—24 in. OAW
—	B-15988	LH Spur—12 in. thru 18 in. OAW
—	B-14847	LH Spur—24 in. OAW
27	—	18 in. Tangent Channel—LH
—	B-15984-18L	12 in. thru 18 in. OAW
—	B-14866-L	24 in. OAW
28	—	18 in. Tangent Channel—RH
—	B-15984-18R	12 in. thru 18 in. OAW
—	B-14866-18R	24 in. OAW
29	B-14860	Coupling Angle
30	B-14756	Butt Coupling
31	—	V-Belt (Drive)
—	066.614	B-124 (12 in. thru 18 in. OAW)
—	066.608	B-150 (24 in. OAW)
32	B-05477	Threaded Section Spacer—Curve Portion (Specify BR)
33	—	Threaded Section Spacer—Straight Portion
—	040.105	10 in. BR (Bolt)
—	040.106	13 in. BR (Bolt)
—	040.107	16 in. BR (Bolt)
—	B-05477-022	22 in. BR (Pipe)
34	B-03102	Take-Up Bracket (Specify BR)
35	B-03092	Threaded Take-Up Rod (Specify Length)
36	B-03091	Sheave Take-Up Angle
37	041.201	Hex Jam Nut—1/2-13
38	024.1216	V-Idler Sheave—4 in. O.D. x 5/8 in. Bore
39	098.157	Spacer—687 I.D. x 1 in. O.D. x .25 Long
40	041.104	Hex Nut—5/8-11
41	043.104	Flat Washer—5/8 in. I.D.
42	043.204	Split Lockwasher—5/8 in. I.D.
43	040.5031	Hex Head Cap Screw—5/8-11 x 2-3/4 in. Long
44	B-03195	Fixed Idler Bracket (Specify BR)
45	024.1226	Flat-Idler Sheave—5-1/2 in. O.D. x 5/8 in. Bore
46	B-21900	Take-Up Sheave Spacer
47	040.5034	Hex Head Cap Screw—5/8-11 x 3-1/2 in. Long
48	024.12431	V-Idler Sheave—2-1/2 in. O.D. x 3/8 in. Bore with Spacer
49	043.101	Flat Washer—5/16 in. I.D.
50	049.5285	Flange Locknut—3/8 in.-16
51	—	Spur Plate
—	B-14488	12 in. thru 18 in. OAW (Specify)
—	B-15407	24 in. OAW
52	B-05605	Spur Plate Stiffener (Specify Length)
53	B-14786	Coupling—Long Spur Channel
54	B-14787	Coupling—Short Spur Channel
55	—	Spur Roller Bracket
—	B-15370	12 in. thru 18 in. OAW (Specify)
—	B-04415	24 in. OAW
56	G-00571-004	K-Bracket—6-1/2 in. Channel

Ref. No.	Part No.	Description
57	—	1-3/8 in. Dia. Spur Roller 12 in. thru 18 in. OAW (Specify)
—	B-16276	One Groove Without Spring.—2-29/32 in. Between Brackets
—	B-16277	Two Groove—4-13/32 in. Between Brackets
—	B-16282-003	5-29/32 in. Between Brackets
—	B-16282-004	7-13/32 in. Between Brackets
—	B-16282-005	8-29/32 in. Between Brackets
—	B-16282-006	10-13/32 in. Between Brackets
—	B-16282-007	11-29/32 in. Between Brackets
—	B-16282-008	13-13/32 in. Between Brackets
—	B-16282-009	14-29/32 in. Between Brackets
—	—	1.9 in. Dia. Spur Roller—24 in. OAW
—	G-00420-024	Without Spring 3 in. Between Brackets
—	B-01982-048	6 in. Between Brackets
—	B-01982-072	9 in. Between Brackets
—	B-01982-096	12 in. Between Brackets
—	B-01982-120	15 in. Between Brackets
—	B-01982-144	18 in. Between Brackets
—	B-01982-168	21 in. Between Brackets
58	—	One Groove Roller
—	B-06533	1-3/8 in. Dia. 12 in. thru 18 in. OAW (Specify BR)
—	B-06535-176	1.9 in. Dia. 24 in. OAW
59	B-06534	Two Groove Roller 12 in. thru 18 in. OAW (Specify BR)
60	—	Tread Roller
—	B-03935	1-3/8 in. Dia. 12 in. thru 18 in. OAW (Specify BR)
—	B-01982-176	1.9 in. Tapered 24 in. OAW (Straight Portion)
—	G-00846-176	1.9 in. Tapered 24 in. OAW (Curve Portion)
61	—	O-Ring—1/8 in. Dia.
—	090.2548	12 in. thru 18 in. OAW
—	090.255	24 in. OAW
62	B-09799	End Guard (Specify OAW)
63	092.159	V-Belt Shield (24 in. OAW Only)
64	049.317	Self-Tapping Hex Screw—1/4-20 x 3/4 in. Long 24 in. OAW
65	—	LS Type Pivot Plate—1-1/8 in. Flange
—	G-00248	4 in. High
—	G-00249	1-7/8 in. High
66	—	Floor Support Frame
—	B-00914	6 in. High (Specify OAW)
—	B-12777	7 in. High (Specify OAW)
—	B-12778	8 in. High (Specify OAW)
—	B-00915	9 in. High (Specify OAW)
—	B-00916	11-1/2 in. High (Specify OAW)
—	B-00917	14-1/2 in. High (Specify OAW)
—	B-02098	18-1/2 in. High (Specify OAW)
—	B-00919	22-1/2 in. High (Specify OAW)
—	B-00921	32-1/2 in. High (Specify OAW)
—	B-00923	44-1/2 in. High (Specify OAW)
—	B-00925	56-1/2 in. High (Specify OAW)
—	B-02107	68-1/2 in. High (Specify OAW)
—	B-02109	78-1/2 in. High (Specify OAW)
—	B-02111	90-1/2 in. High (Specify OAW)
67	B-00909	Center Support Leg (Specify Length)
68	B-00911	Adjustable Foot Assembly (Specify Length)

TAPERED ROLLER SPUR

69	—	Inside Channel
—	B-15339	12 in. thru 18 in. OAW
—	B-15341	24 in. OAW
70	—	Outside Channel
—	B-15340	12 in. thru 18 in. OAW (Specify)
—	B-15342	24 in. OAW
71	B-14865-18L	18 in. Long Tangent Channel - LH
72	B-14865-18R	18 in. Long Tangent Channel - RH
73	—	Long Straight Channel
—	B-14846	12 in. thru 18 in. OAW
—	B-15350	24 in. OAW
74	—	Short Straight Channel
—	B-14844	LH Spur - 12 in. thru 18 in. OAW (Specify)
—	B-15351	LH Spur - 24 in. OAW
—	B-14845	RH Spur - 12 in. thru 18 in. OAW (Specify)
—	B-15352	RH Spur - 24 in. OAW
75	B-15247	Spur Roller Bracket
76	—	1-3/8 in. Spur Roller
—	B-15377	2-29/32 in. Between Brackets
—	B-15378	4-13/32 in. Between Brackets
—	B-15251-003	5-29/32 in. Between Brackets
—	B-15251-004	7-13/32 in. Between Brackets
—	B-15251-005	8-29/32 in. Between Brackets
—	B-15251-006	10-13/32 in. Between Brackets
—	B-15251-007	11-29/32 in. Between Brackets
—	B-15251-008	13-13/32 in. Between Brackets
—	B-15251-009	14-29/32 in. Between Brackets
—	B-15251-010	16-13/32 in. Between Brackets
—	B-15251-011	17-29/32 in. Between Brackets
—	B-15251-012	19-13/32 in. Between Brackets
—	B-15251-013	20-29/32 in. Between Brackets
77	G-02680	1-3/8 in. Dia. Roller (Specify BR)
78	B-15156	1-3/8 in. Dia. Single Groove Roller (Specify BR)
79	B-15157	1-3/8 in. Dia. Single Groove Roller (Specify BR)
80	B-15371	1-3/8 in. Tapered Roller (Specify BR)
81	—	Spacer Rod - 5/16 in. Threaded Rod
—	044.1142	12 in. OAW
—	044.1144	15 in. OAW
—	044.1146	18 in. OAW
—	044.1148	24 in. OAW

● Model 138-LRS 30° Parts Drawing



Dibujo de Partes del Modelo 138-LRS 30°

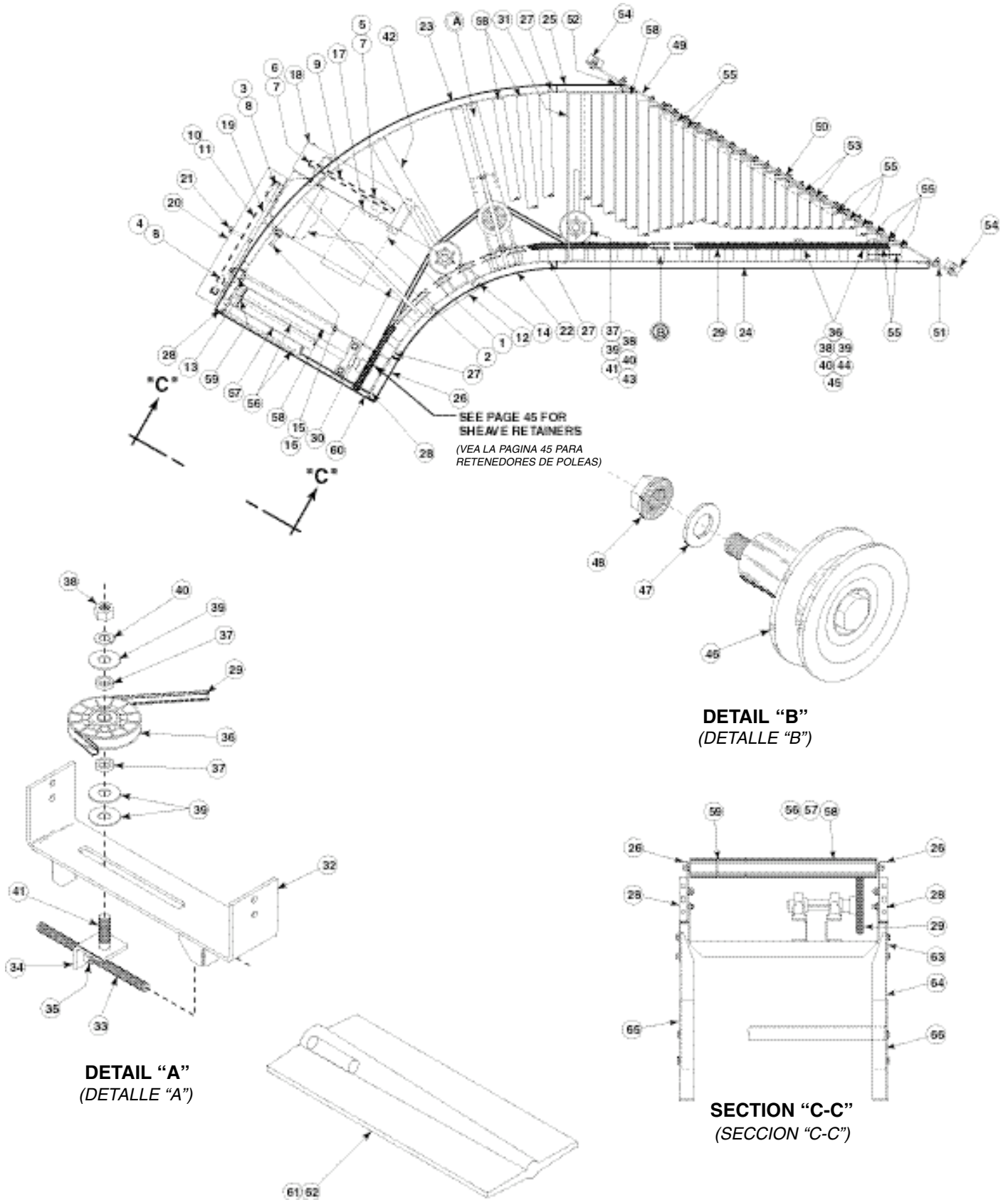

*See Page 46 for Slave Connection
(*Vea la Página 46 para la Conexión Esclavada)

● Model 138-LRS 30° Parts List

Lista de Partes del Modelo 138-LRS 30°



See Page 25 for Information on How To Order Replacement Parts

Veá la Página 25 para información sobre como ordenar partes de repuesto

Recommended Spare Parts Highlighted In Gray

Partes de Repuesto Recomendadas se Resaltan en Gris

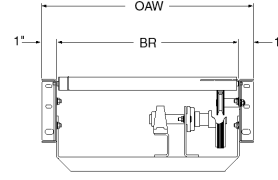

Ref. No.	Part No.	Description
1	—	Motor—Foot Mounted
2	030.2034	1/2 Hp—230/460 VAC—3 Ph.—60 Hz.—TEFC
3	—	4A Speed Reducer
4	—	RH—20:1 Ratio
5	R-00152-20R	LH—20:1 Ratio
6	R-00152-20L	—
7	028.1005	Sprocket—Reducer, 50B12 x 1 in. Bore
8	028.133	Sprocket—Drive Shaft, 50B14 x 1 in. Bore
9	020.104	Sheave—Motor, 3,00 in. O.D. x 5/8 in. Bore
10	020.120	Sheave—Reducer, 5,00 in. O.D. x 3/4 in. Bore
11	090.202	Shaft Key—3/16 in. Sq. x 1 in. Long
12	090.203	Shaft Key—1/4 in. Sq. x 1 in. Bore
13	—	V-Belt (Motor to Reducer)
14	066.105	4L270 (12 in. thru 15 in. OAW)
15	066.109	4L310 (18 in. thru 24 in. OAW)
16	029.101	#50 Riveted Roller Chain
17	029.201	Connector Link—#50 Roller Chain
18	—	Motor Base Assembly
19	B-15424	RH Reducer—12 in. thru 18 in. OAW (Specify)
20	B-15426	RH Reducer—24 in. OAW
21	B-15425	LH Reducer—12 in. thru 18 in. OAW (Specify)
22	B-15427	LH Reducer—24 in. OAW
23	098.1505	Spacer—13/32 in. I.D. x 3/4 in. O.D. x 1-1/8 in. Long
24	098.1681	Spacer—13/32 in. I.D. x 1 in. O.D. x 2.304 in. Long
25	040.307	Take-Up Bolt—3/8-16 x 2-1/4 in. Long
26	041.300	Hex Jam Nut—Heavy—3/8-16
27	—	Inside V-Belt Guard
28	B-05275	14 in. Long—RH Reducer—12 in. thru 18 in. OAW
29	B-05120	16 in. Long—RH Reducer—18 in. thru 24 in. OAW
30	B-06580	14 in. Long—LH Reducer—12 in. thru 15 in. OAW
31	B-05558	16 in. Long—LH Reducer—18 in. thru 24 in. OAW
32	—	Outside V-Belt Guard
33	B-05274	14 in. Long—12 in. thru 15 in. OAW
34	B-05119	16 in. Long—18 in. thru 24 in. OAW
35	—	Chain Guard Back Plate
36	B-15109	RH Reducer
37	B-15110	LH Reducer
38	B-15112	Chain Guard Front Plate
39	041.919	Acorn Nut—3/8-16
40	—	Inside Channel
41	B-15979	12 in. thru 28 in. OAW
42	B-14836	24 in. OAW
43	—	Outside Channel
44	B-15980	12 in. thru 18 in. OAW (Specify)
45	B-14837	24 in. OAW
46	—	Long Straight Channel
47	B-15987	12 in. thru 18 in. OAW
48	B-14843	24 in. OAW
49	—	Short Straight Channel
50	B-15986	RH Spur—12 in. thru 18 in. OAW (Specify)
51	B-14842	RH Spur—24 in. OAW
52	B-15985	LH Spur—12 in. thru 18 in. OAW (Specify)
53	B-14841	LH Spur—24 in. OAW
54	—	6-1/4 in. Tangent Channel
55	B-15983	12 in. thru 18 in. OAW
56	B-14862	24 in. OAW
57	B-14860	Coupling Angle
58	B-14756	Butt Coupling
59	—	V-Belt (Drive)
60	066.1318	B-133 (12 in. thru 18 in. OAW)
61	066.1328	B-173 (24 in. OAW)
62	B-05477	Threaded Section Spacer—Curve Position (Specify BR)
63	—	Threaded Section Spacer—Straight Position
64	040.105	10 in. BR (Bolt)
65	040.106	13 in. BR (Bolt)
66	040.107	16 in. BR (Bolt)
67	B-05477-022	22 in. (Pipe)
68	B-03102	Take-Up Bracket (Specify BR)
69	B-03092	Threaded Take-Up Rod (Specify Length)
70	B-03091	Sheave Take-Up Angle
71	041.201	Hex Jam Nut—1/2-13
72	024.1216	V-Idler Sheave—4 in. O.D. x 5/8 in. Bore
73	098.1565	Spacer—687 I.D. x 1 in. O.D. x .25 Long
74	041.104	Hex Nut—5/8-11
75	043.104	Flat Washer—5/8 in. I.D.
76	043.204	Split Lockwasher—5/8 in. I.D.
77	040.5031	Hex Head Cap Screw—5/8-11 x 2-3/4 in. Long
78	B-03195	Fixed Idler Bracket (Specify BR)
79	024.1226	Flat Idler Sheave—5-1/2 in. O.D. x 5/8 in. Bore
80	B-21900	Take-Up Sheave Spacer
81	040.5034	Hex Head Cap Screw—5/8-11 x 3-1/2 in. Long
82	024.12431	V-Idler Sheave—2-1/2 in. O.D. x 3/8 in. Bore
83	043.101	Flat Washer—5/16" I.D.
84	049.5285	Flange Locknut—3/8-16
85	—	Spur Plate
86	B-14487	12 in. thru 18 in. OAW (Specify)
87	B-15406	24 in. OAW
88	B-05605	Spur Plate Stiffener (Specify Length)
89	B-14784	Coupling—Long Spur Channel
90	B-14785	Coupling—Short Spur Channel
91	—	Spur Roller Bracket
92	B-15369	12 in. thru 18 in. OAW
93	B-04519	24 in. OAW
94	G-00571-004	K-Bracket—6-1/2 in. Channel
95	—	1-3/8 in. Dia. Spur Roller 12 in. thru 18 in. OAW (Specify)
96	B-16268	One Groove Without Spring—1-11/16 in. Between Brackets
97	B-16269	Two Grooves—2-9/16 in. Between Brackets
98	B-16270	Two Grooves—3-13/32 in. Between Brackets
99	B-16274-004	4-9/32 in. Between Brackets
100	B-16274-005	5-5/32 in. Between Brackets
101	B-16274-006	6 in. Between Brackets
102	B-16274-007	6-7/8 in. Between Brackets
103	B-16274-008	7-3/4 in. Between Brackets
104	B-16274-009	8-5/8 in. Between Brackets
105	B-16274-010	9-15/32 in. Between Brackets
106	B-16274-011	10-11/32 in. Between Brackets
107	B-16274-012	11-7/32 in. Between Brackets
108	B-16274-013	12-1/16 in. Between Brackets

Ref. No.	Part No.	Description
—	B-16274-014	12-15/16 in. Between Brackets
—	B-16274-015	13-13/16 in. Between Brackets
—	B-16274-016	14-11/16 in. Between Brackets
—	B-16274-017	15-17/32 in. Between Brackets
—	—	1.9 in. Dia. Spur Roller 24 in. OAW
—	G-00420-014	Without Spring—1-3/4 in. Between Brackets
—	G-00420-028	Without Spring—3-1/2 in. Between Brackets
—	B-01982-041	5-1/8 in. Between Brackets
—	B-01982-055	6-7/8 in. Between Brackets
—	B-01982-069	8-5/8 in. Between Brackets
—	B-01982-083	10-1/2 in. Between Brackets
—	B-01982-097	12-1/8 in. Between Brackets
—	B-01982-111	13-7/8 in. Between Brackets
—	B-01982-125	15-5/8 in. Between Brackets
—	B-01982-138	17-1/4 in. Between Brackets
—	B-01982-152	19 in. Between Brackets
—	B-01982-166	20-3/4 in. Between Brackets
56	—	One Groove Roller
—	B-06533	1-3/8 in. Dia. 12 in. thru 18 in. OAW (Specify BR)
—	B-06535-176	1.9 in. Dia. 24 in. OAW
57	B-06534	Two Grooves Roller 12 in. thru 18 in. OAW (Specify BR)
58	—	Tread Roller
—	B-03935	1-3/8 in. Dia. 12 in. thru 18 in. OAW (Specify BR)
—	B-01982-176	1.9 in. Straight 24 in. OAW (Straight Portion)
—	G-00486-176	1.9 in. Tapered 24 in. OAW (Curve Portion)
59	—	O-Ring—1/8 in. Dia.
—	090.2548	12 in. thru 18 in. OAW
—	090.255	24 in. OAW
60	B-09799	End Guard (Specify OAW)
61	092.159	V-Belt Shield (24 in. OAW Only)
62	049.317	Self-Tapping Hex Screw—1/4-20 x 3/4 in. Lg. 24 in. OAW
63	—	L3 Type Pivot Plate—1-1/8 in. Flange
—	G-00248	4 in. High
—	G-00249	1-7/8 in. High
64	—	Floor Support Frame
—	B-00914	6 in. High (Specify OAW)
—	B-12777	7 in. High (Specify OAW)
—	B-12778	8 in. High (Specify OAW)
—	B-00915	9 in. High (Specify OAW)
—	B-00916	11-1/2 in. High (Specify OAW)
—	B-00917	14-1/2 in. High (Specify OAW)
—	B-02098	18-1/2 in. High (Specify OAW)
—	B-00919	22-1/2 in. High (Specify OAW)
—	B-00921	32-1/2 in. High (Specify OAW)
—	B-00923	44-1/2 in. High (Specify OAW)
—	B-00925	56-1/2 in. High (Specify OAW)
—	B-02107	68-1/2 in. High (Specify OAW)
—	B-02109	78-1/2 in. High (Specify OAW)
—	B-02111	90-1/2 in. High (Specify OAW)
65	B-00909	Center Support Leg (Specify Length)
66	B-00911	Adjustable Foot Assembly (Specify Length)

TAPERED ROLLER SPUR		
67	—	Inside Channel
—	B-15335	12 in. thru 18 in. OAW
—	B-15337	24 in. OAW
68	—	Outside Channel
—	B-15336	12 in. thru 18 in. OAW (Specify)
—	B-15338	24 in. OAW
69	B-14861	6-1/4 in. Long Tangent Channel
70	—	Long Straight Channel
—	B-14840	12 in. thru 18 in. OAW
—	B-15347	24 in. OAW
71	—	Short Straight Channel
—	B-14838	LH Spur - 12 in. thru 18 in. OAW (Specify)
—	B-15348	LH Spur - 24 in. OAW
—	B-14839	RH Spur - 12 in. thru 18 in. OAW (Specify)
—	B-15349	RH Spur - 24 in. OAW
72	B-15246	Spur Roller Bracket
73	—	1-3/8 in. Spur Roller
—	B-15372	1-11/16 in. Between Brackets
—	B-15373	2-9/16 in. Between Brackets
—	B-15374	3-13/32 in. Between Brackets
—	B-15248-004	4-9/32 in. Between Brackets
—	B-15248-005	5-5/32 in. Between Brackets
—	B-15248-006	6 in. Between Brackets
—	B-15248-007	6-7/8 in. Between Brackets
—	B-15248-008	7-3/4 in. Between Brackets
—	B-15248-009	8-5/8 in. Between Brackets
—	B-15248-010	9-15/32 in. Between Brackets
—	B-15248-011	10-11/32 in. Between Brackets
—	B-15248-012	11-7/32 in. Between Brackets
—	B-15248-013	12-1/16 in. Between Brackets
—	B-15248-014	12-15/16 in. Between Brackets
—	B-15248-015	13-13/16 in. Between Brackets
—	B-15248-016	14-11/16 in. Between Brackets
—	B-15248-017	15-17/32 in. Between Brackets
—	B-15248-018	16-13/32 in. Between Brackets
—	B-15248-019	17-9/32 in. Between Brackets
—	B-15248-020	18-1/8 in. Between Brackets
—	B-15248-021	19 in. Between Brackets
—	B-15248-022	19-7/8 in. Between Brackets
—	B-15248-023	20-23/32 in. Between Brackets
—	B-15248-024	21-19/32 in. Between Brackets
74	G-02680	1-3/8 in. Dia. Roller (Specify BR)
75	B-15156	1-3/8 in. Dia. Single Groove Roller (Specify BR)
76	B-15157	1-3/8 in. Dia. Single Groove Roller (Specify BR)
77	B-15371	1-3/8 in. Tapered Roller (Specify BR)
78	—	Spacer Rod - 5/16 in. Threaded Rod
—	044.1142	12 in. OAW
—	044.1144	15 in. OAW
—	044.1146	18 in. OAW
—	044.1148	24 in. OAW

● Model 138-LRSS 45° Parts Drawing
 Dibujo de Partes del Modelo 138-LRSS 45°

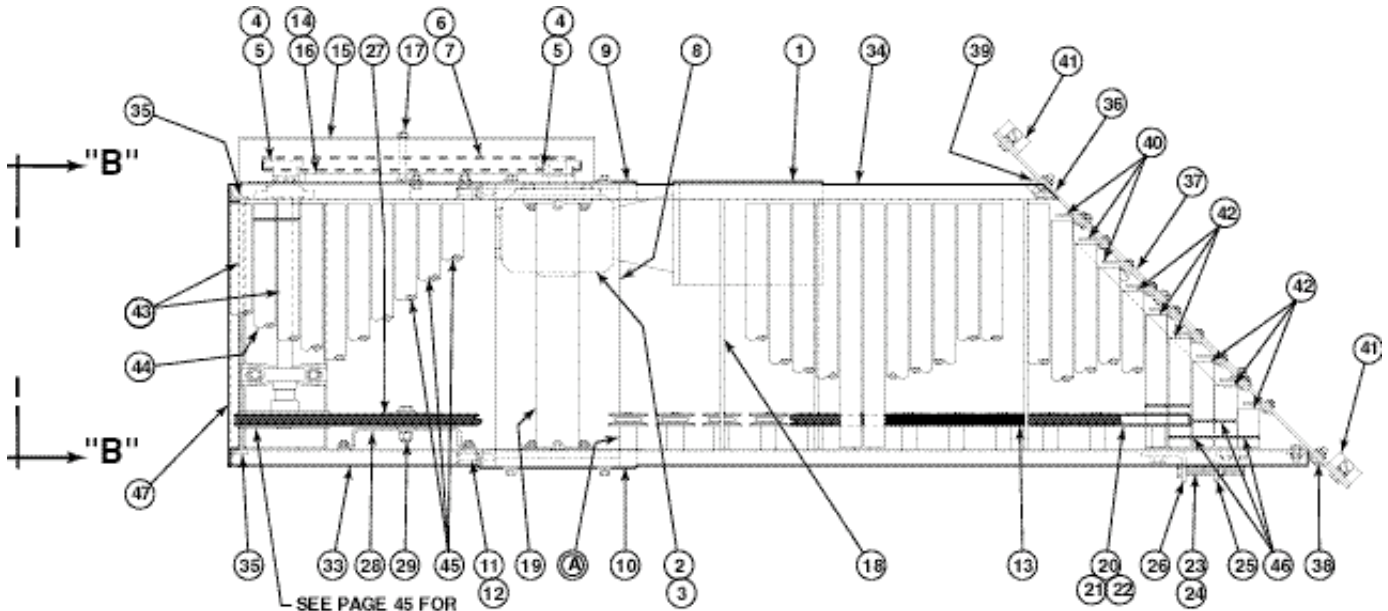

SEE PAGE 45 FOR
 SHEAVE RETAINERS
 (VEA LA PAGINA 45 PARA
 RETENEDORES DE POLEA)

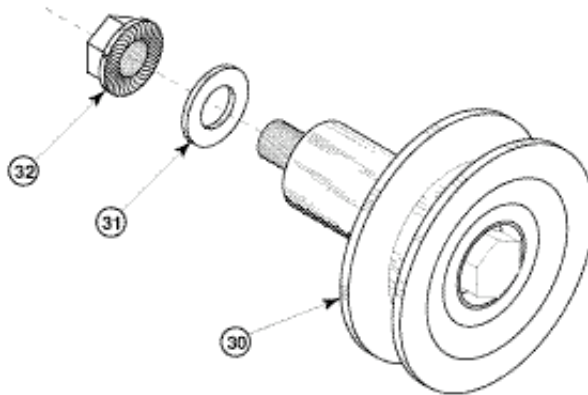

DETAIL "A"
 (DETALLE "A")

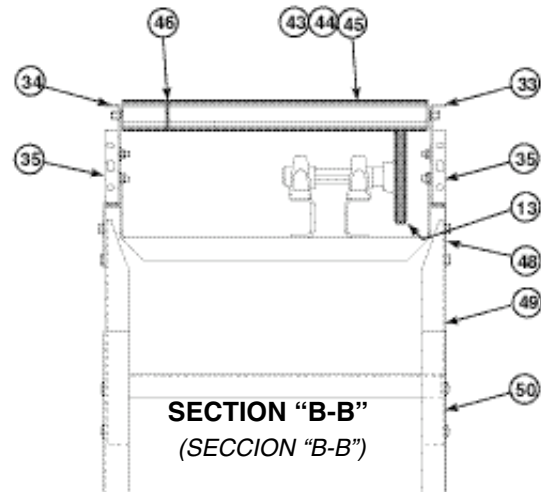

SECTION "B-B"
 (SECCION "B-B")

*See Page 46 for Slave Connection
 (*Vea la Página 46 para la Conexión Esclavada)

● Model 138-LRSS 45° Parts List

Lista de Partes del Modelo 138-LRSS 45°



See Page 25 for Information on How To Order Replacement Parts

Veá la Página 25 para información sobre como ordenar partes de repuesto

Recommended Spare Parts Highlighted In Gray

Partes de Repuesto Recomendadas se Resaltan en Gris

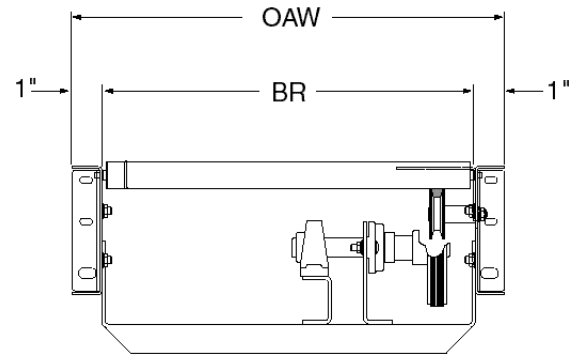

Ref. No.	Part No.	Description
1	—	Motor—C-Face
—	030.7134	1/2 Hp—230/460 VAC—3 Ph.—60 Hz.—TEFC
2	—	4AC Speed Reducer
—	R-00153-40R	RH—40:1 Ratio
—	R-00153-40L	LH—40:1 Ratio
3	052.145	Coupling kit - Motor To Reducer
4	028.119	Sprocket— 50B13 x 1 in. Bore
5	090.203	Shaft Key—1/4 in. Sq. x 1 in. Long
6	029.101	#50 Riveted Roller Chain
7	029.201	Connector Link—#50 Roller Chain
8	B-06629	Motor Base Assembly (Specify OAW)
9	B-15008	Motor Base Support Angle—LH
10	B-15009	Motor Base Support Angle—RH
11	040.307	Take-Up Bolt—3/8-16 x 2-1/4 in. Long
12	041.300	Hex Jam Nut—Heavy—3/8-16
13	066.146	V-Belt (Drive)
14	B-21222	Chain Guard Back Plate
15	B-21223	Chain Guard Front Plate
16	B-14492	Chain Guard Mounting Angle
17	041.919	Acorn Nut—3/8-16
18	040.105	Threaded Spacer 12 in. OAW
—	040.106	Threaded Spacer 15 in. OAW
—	040.107	Threaded Spacer 18 in. OAW
—	040.108	Threaded Spacer 24 in. OAW
19	B-03916	Bed Spacer (Specify BR)
20	024.1216	V-Idler Sheave—4 in. O.D. x 5/8 in. Bore
21	B-21900	Take-Up Sheave Spacer
22	040.5034	Hex Head Cap Screw—5/8-11 x 3-1/2 in. Long
23	040.407	Hex Head Cap Screw—1/2-13 x 4 in. Long
24	041.201	Hex Jam Nut—1/2-13
25	B-05324	Angle Bracket
26	B-05325	Angle Bracket
27	024.133	Flat Idler Sheave—3-1/4 in. O.D. x 1/2 in. Bore
28	B-04177	Snub Return Idler Bracket
29	040.404	Hex Head Cap Screw—1/2-13 x 2 in. Long
30	024.12431	Sheave—2-1/2 in. O.D. x 3/8 in. Bore with Spacer
31	043.101	Flat Washer 5/16 in. I.D.
32	049.5285	Flange Locknut—3/8 in.-16
33	B-15995	Long Straight Channel
34	—	Short Straight Channel
—	B-15993	LH Spur (Specify BR)
—	B-15994	RH Spur (Specify BR)
35	B-14756	Butt Coupling
36	B-14488	Spur Plate (Specify OAW)

Ref. No.	Part No.	Description
37	B-05605	Spur Plate Stiffener (Specify Length)
38	B-14786	Coupling—Long Spur Channel
39	B-14787	Coupling—Short Spur Channel
40	B-15370	Spur Roller Bracket
41	G-00571-004	K-Bracket—6-1/2 in. Channel
42	—	1-3/8 in. Dia. Spur Roller
—	B-16276	1 Groove W/out Spring 2-29/32 in. Between Brackets
—	B-16277	2 Groove 4-13/32 in. Between Brackets
—	B-16278	2 Groove 5-29/32 in. Between Brackets
—	B-16279	2 Groove 7-13/32 in. Between Brackets
—	B-16280	2 Groove 8-29/32 in. Between Brackets
—	B-16282-006	10-13/32 in. Between Brackets
—	B-16282-007	11-29/32 in. Between Brackets
—	B-16282-008	13-13/32 in. Between Brackets
—	B-16282-009	14-29/32 in. Between Brackets
—	B-16282-010	16-13/32 in. Between Brackets
—	B-16282-011	17-29/32 in. Between Brackets
—	B-16282-012	19-13/32 in. Between Brackets
—	B-16282-013	20-29/32 in. Between Brackets
43	B-06533	1-3/8 in. Dia. Roller—One Groove (Specify BR)
44	B-06534	1-3/8 in. Dia. Roller—Two Grooves (Specify BR)
45	B-03935	1-3/8 in. Dia. Roller (Specify BR)
46	090.2548	O-Ring—1/8 in. Dia.
47	B-09799	End Guard (Specify OAW)
48	—	LS Type Pivot Plate—1-1/8 in. Flange
—	G-00248	4 in. High
—	G-00249	1-7/8 in. High
49	—	Floor Support Frame
—	B-00914	6 in. High (Specify OAW)
—	B-12777	7 in. High (Specify OAW)
—	B-12778	8 in. High (Specify OAW)
—	B-00915	9 in. High (Specify OAW)
—	B-00916	11-1/2 in. High (Specify OAW)
—	B-00917	14-1/2 in. High (Specify OAW)
—	B-02098	18-1/2 in. High (Specify OAW)
—	B-00919	22-1/2 in. High (Specify OAW)
—	B-00921	32-1/2 in. High (Specify OAW)
—	B-00923	44-1/2 in. High (Specify OAW)
—	B-00925	56-1/2 in. High (Specify OAW)
—	B-02107	68-1/2 in. High (Specify OAW)
—	B-02109	78-1/2 in. High (Specify OAW)
—	B-02111	90-1/2 in. High (Specify OAW)
50	B-00911	Adjustable Foot Assembly (Specify Length)

● Model 138-LRSS 30° Parts Drawing
 Dibujo de Partes del Modelo 138-LRSS 30°

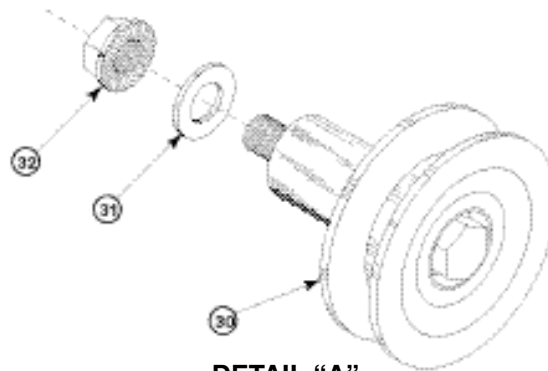
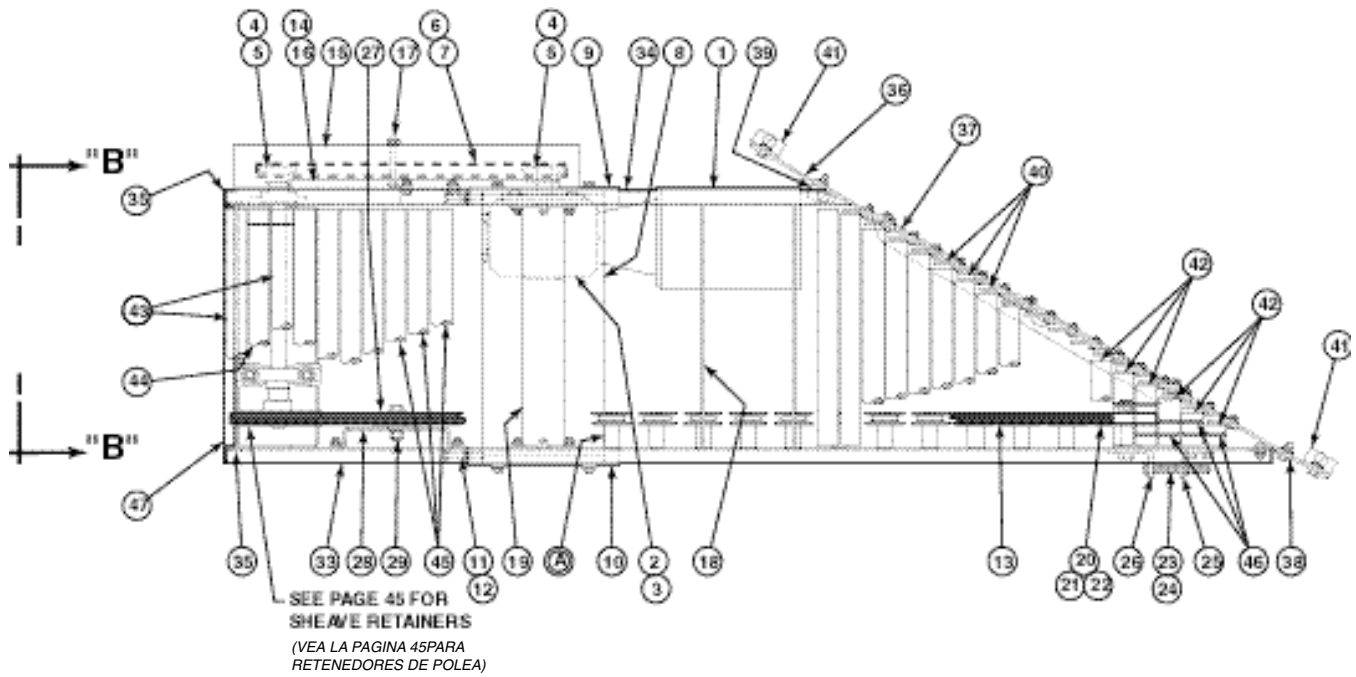

DETAIL "A"
 (DETALLE "A")

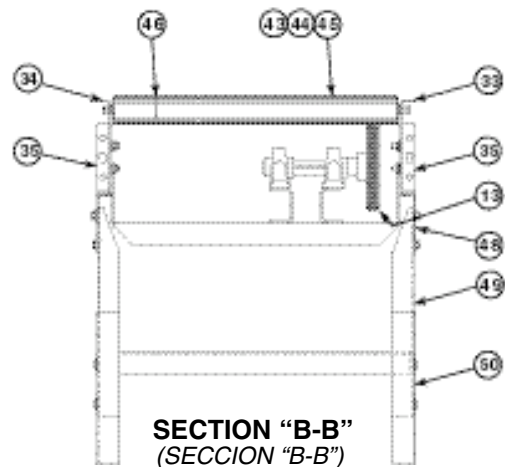

SECTION "B-B"
 (SECCION "B-B")

*See Page 46 for Slave Connection
 (*Vea la Página 46 para la Conexión Esclavada)

● Model 138-LRSS 30° Parts List

Lista de Partes del Modelo 138-LRSS 30°



See Page 25 for Information on How To
Order Replacement Parts

Vea la Página 25 para información sobre como
ordenar partes de repuesto

Recommended Spare Parts Highlighted In Gray

*Partes de Repuesto Recomendadas
se Resaltan en Gris*

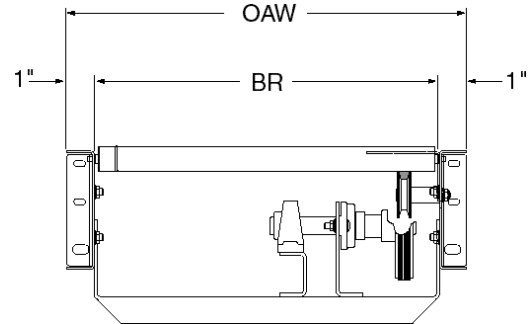

Ref. No.	Part No.	Description
1	—	Motor—C-Face
—	030.7134	1/2 Hp—230/460 VAC—3 Ph.—60 Hz.—TEFC
2	—	4AC Speed Reducer
—	R-00153-40R	RH—40:1 Ratio
—	R-00153-40L	LH—40:1 Ratio
3	052.145	Coupling kit - Motor To Reducer
4	028.119	Sprocket— 50B13 x 1 in. Bore
5	090.203	Shaft Key—1/4 in. Sq. x 1 in. Long
6	029.101	#50 Riveted Roller Chain
7	029.201	Connector Link—#50 Roller Chain
8	B-06629	Motor Base Assembly (Specify OAW)
9	B-15008	Motor Base Support Angle—LH
10	B-15009	Motor Base Support Angle—RH
11	040.307	Take-Up Bolt—3/8-16 x 2-1/4 in. Long
12	041.300	Hex Jam Nut—Heavy—3/8-16
13	066.146	V-Belt (Drive)
14	B-21222	Chain Guard Back Plate
15	B-21223	Chain Guard Front Plate
16	B-14492	Chain Guard Mounting Angle
17	041.919	Acorn Nut—3/8-16
18	040.105	Threaded Spacer 12 in. OAW
—	040.106	Threaded Spacer 15 in. OAW
—	040.107	Threaded Spacer 18 in. OAW
—	040.108	Threaded Spacer 24 in. OAW
19	B-03916	Bed Spacer (Specify BR)
20	024.1216	V-Idler Sheave—4 in. O.D. x 5/8 in. Bore
21	B-21900	Take-Up Sheave Spacer
22	040.5034	Hex Head Cap Screw—5/8-11 x 3-1/2 in. Long
23	040.407	Hex Head Cap Screw—1/2-13 x 4 in. Long
24	041.201	Hex Jam Nut—1/2-13
25	B-05324	Angle Bracket
26	B-05325	Angle Bracket
27	024.133	Flat Idler Sheave—3-1/4 in. O.D. x 1/2 in. Bore
28	B-04177	Snub Return Idler Bracket
29	040.404	Hex Head Cap Screw—1/2-13 x 2 in. Long
30	024.12431	Sheave—2-1/2 in. O.D. x 3/8 in. Bore with Spacer
31	043.101	Flat Washer 5/16 in. I.D.
32	049.5285	Flange Locknut—3/8 in.-16
33	B-15995	Long Straight Channel
34	—	Short Straight Channel
—	B-15991	LH Spur (Specify BR)
—	B-15992	RH Spur (Specify BR)
35	B-14756	Butt Coupling
36	B-14487	Spur Plate (Specify OAW)
37	B-05605	Spur Plate Stiffener (Specify Length)
38	B-14784	Coupling—Long Spur Channel
39	B-14785	Coupling—Short Spur Channel
40	B-15369	Spur Roller Bracket
41	G-00571-004	K-Bracket—6-1/2 in. Channel

Ref. No.	Part No.	Description
42	—	1-3/8 in. Dia. Spur Roller
—	B-16268	1 Groove W/out Spring 1-11/16 in. Between Brackets
—	B-16269	2 Groove 2-9/16 in. Between Brackets
—	B-16270	2 Groove 3-13/32 in. Between Brackets
—	B-16271	2 Groove 4-9/32 in. Between Brackets
—	B-16272	1 Groove 5-5/32 in. Between Brackets
—	B-16274-006	6 in. Between Brackets
—	B-16274-007	6-7/8 in. Between Brackets
—	B-16274-008	7-3/4 in. Between Brackets
—	B-16274-009	8-5/8 in. Between Brackets
—	B-16274-010	9-15/32 in. Between Brackets
—	B-16274-011	10-11/32 in. Between Brackets
—	B-16274-012	11-7/32 in. Between Brackets
—	B-16274-013	12-1/16 in. Between Brackets
—	B-16274-014	12-15/16 in. Between Brackets
—	B-16274-015	13-13/16 in. Between Brackets
—	B-16274-016	14-11/16 in. Between Brackets
—	B-16274-017	15-17/32 in. Between Brackets
—	B-16274-018	16-13/32 in. Between Brackets
—	B-16274-019	17-9/32 in. Between Brackets
—	B-16274-020	18-1/8 in. Between Brackets
—	B-16274-021	19 in. Between Brackets
—	B-16274-022	19-7/8 in. Between Brackets
—	B-16274-023	20-23/32 in. Between Brackets
—	B-16274-024	21-19/32 in. Between Brackets
43	B-06533	1-3/8 in. Dia. Roller—One Groove (Specify BR)
44	B-06534	1-3/8 in. Dia. Roller—Two Grooves (Specify BR)
45	B-03935	1-3/8 in. Dia. Roller (Specify BR)
46	090.2548	O-Ring—1/8 in. Dia.
47	B-09799	End Guard (Specify OAW)
48	—	LS Type Pivot Plate—1-1/8 in. Flange
—	G-00248	4 in. High
—	G-00249	1-7/8 in. High
49	—	Floor Support Frame
—	B-00914	6 in. High (Specify OAW)
—	B-12777	7 in. High (Specify OAW)
—	B-12778	8 in. High (Specify OAW)
—	B-00915	9 in. High (Specify OAW)
—	B-00916	11-1/2 in. High (Specify OAW)
—	B-00917	14-1/2 in. High (Specify OAW)
—	B-02098	18-1/2 in. High (Specify OAW)
—	B-00919	22-1/2 in. High (Specify OAW)
—	B-00921	32-1/2 in. High (Specify OAW)
—	B-00923	44-1/2 in. High (Specify OAW)
—	B-00925	56-1/2 in. High (Specify OAW)
—	B-02107	68-1/2 in. High (Specify OAW)
—	B-02109	78-1/2 in. High (Specify OAW)
—	B-02111	90-1/2 in. High (Specify OAW)
50	B-00911	Adjustable Foot Assembly (Specify Length)

● Model 138-ACC Sheave Retainers Drawings

Retenedores de Polea del Modelo 138-ACC

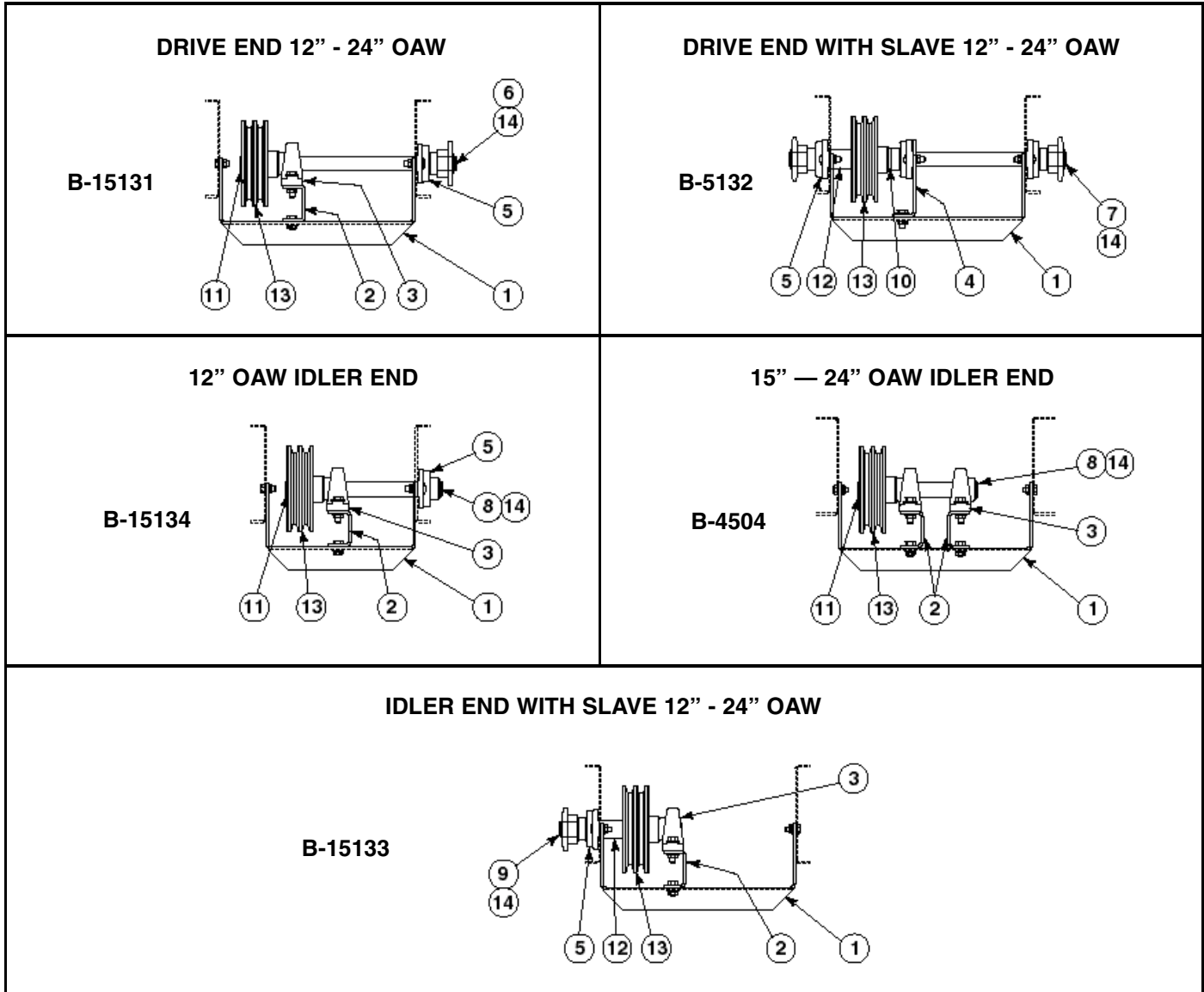

See Page 25 for Information on How To Order Replacement Parts
 Vea la Página 25 para información sobre como ordenar partes de repuesto

Recommended Spare Parts Highlighted In Gray
Partes de Repuesto Recomendadas se Resaltan en Gris

Ref. No.	Part No.	Description
1	—	Sheave Retaining Bracket
—	B-14920	10 in. BR
—	B-14921	13 in. BR
—	B-14471	16 in. thru 22 in. BR (Specify)
2	B-07584	Bearing Pedestal
3	010.3012	Pillow Block Bearing—1 in. Bore
4	B-14719	Flange Bearing Bracket
5	010.0022	2-Bolt Flange Bearing—1 in. Bore
6	B-14388	Drive Shaft (Specify BR)
7	B-14386	Drive Shaft with Slave (Specify BR)

Ref. No.	Part No.	Description
8	—	Idler Shaft
—	B-14385	12 in. OAW
—	B-17066	15 in. thru 24 in. OAW
9	B-15386	Idler Shaft with Slave
10	049.201	Spacer—1 in. I.D. x 1-1/4 in. O.D. x 1/8 in. Long
11	098.1537	Spacer—1 in. I.D. x 1-1/4 in. O.D. x 11/16 in. Long
12	B-10776	Spacer—1 in. I.D. x 1-1/4 in. O.D. x 2-3/8 in. Long
13	024.1282	Drive Sheave (Double)—5-3/4 in. O.D. x 1 in. Bore
14	049.305	External Retaining Ring—1 in. Dia. Shaft

● 138-LRC, LRS, & LRSS Sheave Retainers Drawings

Retenedores de Polea Modelos 138-LRC, LRS & LRSS

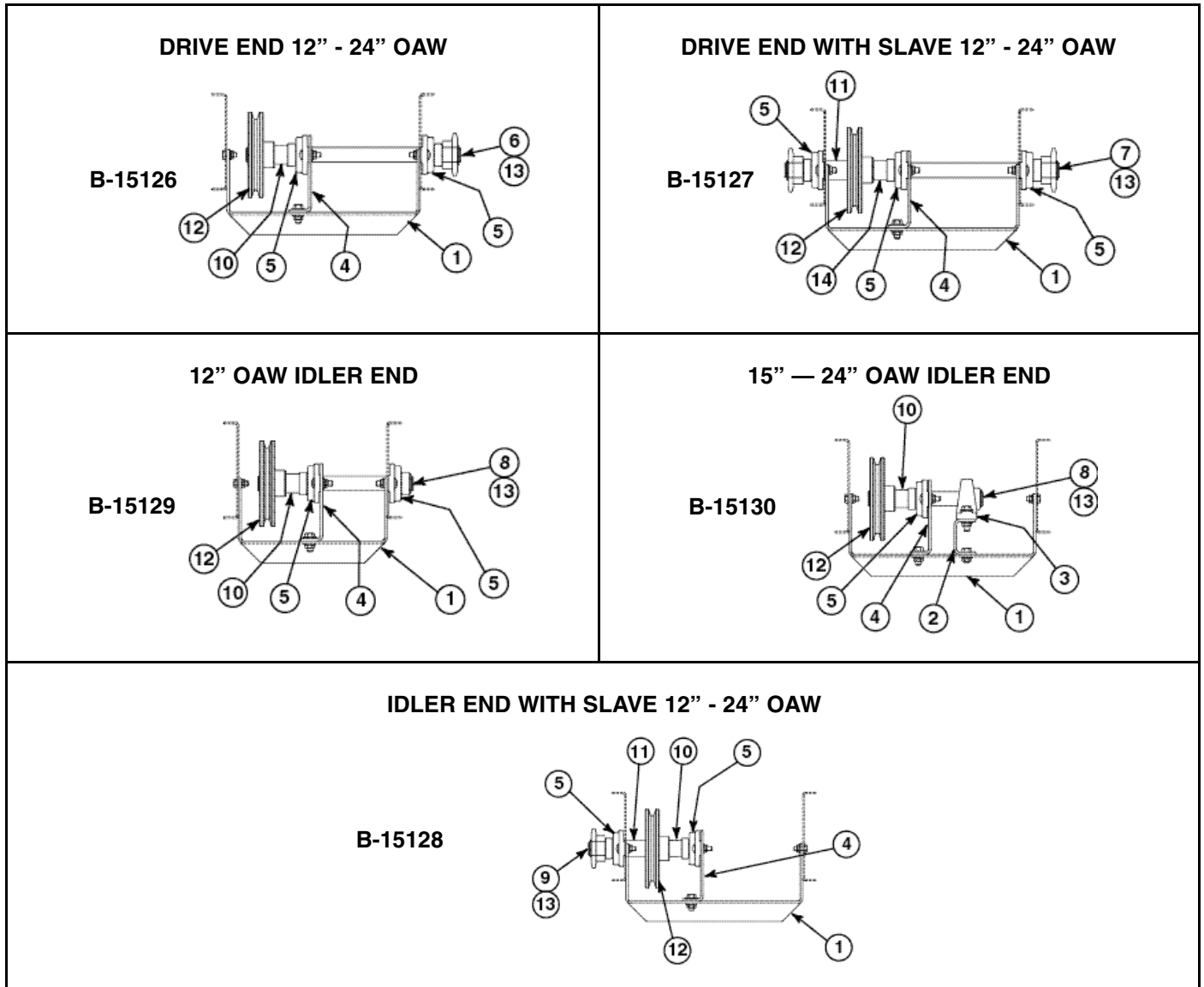

See Page 25 for Information on How To Order Replacement Parts

Veá la Páginá 25 para información sobre como ordenar partes de repuesto

Recommended Spare Parts Highlighted In Gray

Partes de Repuesto Recomendadas se Resaltan en Gris

Ref. No.	Part No.	Description
1	—	Sheave Retaining Bracket
—	B-14920	10 in. BR
—	B-14921	13 in. BR
—	B-14471	16 in. thru 22 in. BR (Specify)
2	B-07584	Bearing Pedestal
3	010.3012	Pillow Block Bearing—1 in. Bore
4	B-14719	Flange Bearing Bracket
5	010.0022	2-Bolt Flange Bearing—1 in. Bore
6	B-14388	Drive Shaft (Specify BR)
7	B-14386	Drive Shaft with Slave (Specify BR)

Ref. No.	Part No.	Description
8	—	Idler Shaft
—	B-14385-012	12 in. OAW
—	B-17066	15 in. thru 24 in. OAW
9	B-22628	Idler Shaft with Slave
10	098.1538	Spacer—1 in. I.D. x 1-1/4 in. O.D. x 13/16 in. Long
11	098.169	Spacer—1 in. I.D. x 1-1/4 in. O.D. x 1-5/8 in. Long
12	024.128	Drive Sheave (Single)—5-3/4 in. O.D. x 1 in. Bore
13	049.305	External Retaining Ring—1 in. Dia. Shaft
14	098.1541	Spacer—1 in. I.D. x 1-1/4 in. O.D. x 29/32 in. Long

● **Slave Connection Parts Drawing & Part List**
Dibujo y Lista de Partes de la Conexión Esclavada

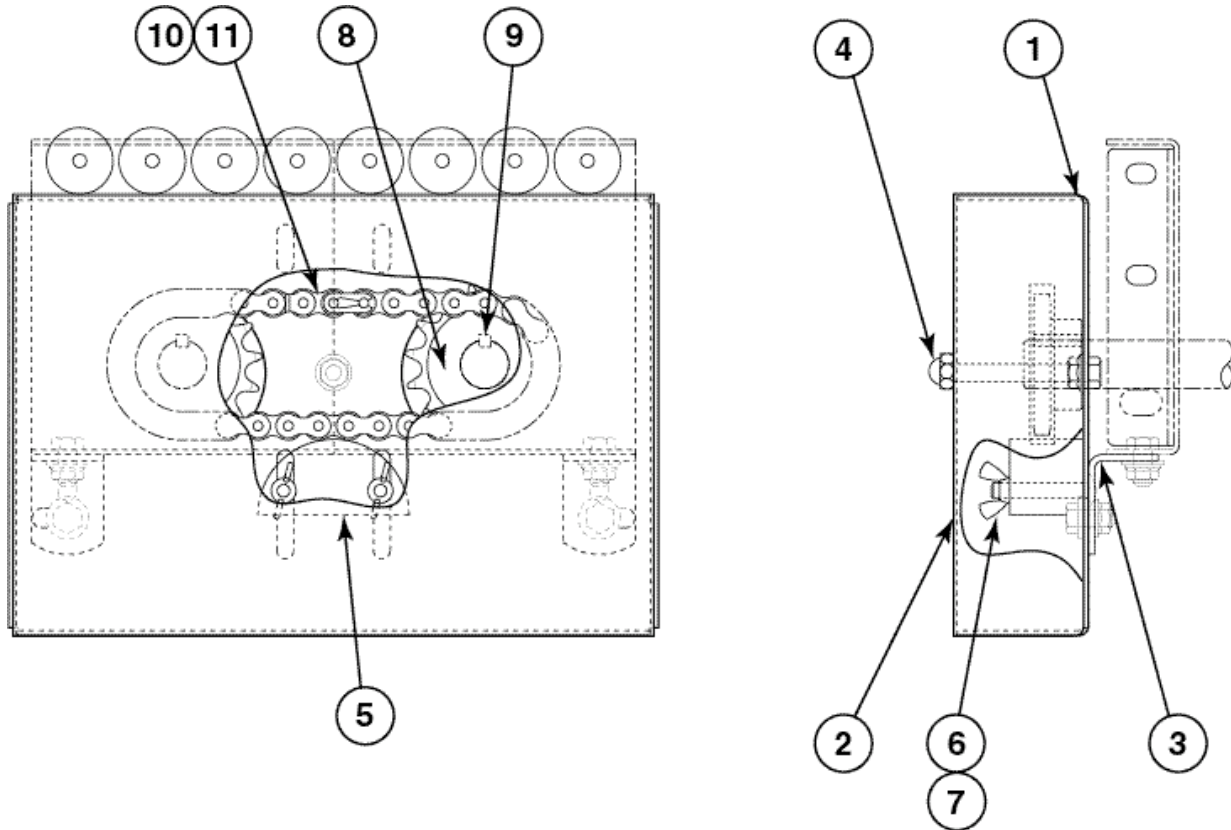

See Page 25 for Information on How To Order Replacement Parts

Vea la Página 25 para información sobre como ordenar partes de repuesto

Recommended Spare Parts Highlighted In Gray
Partes de Repuesto Recomendadas se Resaltan en Gris

Ref. No.	Part No.	Description
1	B-15239	Chain Guard Back Plate
2	B-15241	Chain Guard Front Plate
3	B-16679	Chain Guard Mounting Bracket
4	041.919	Acorn Nut—3/8-16
5	099.496	Take-Up Block
6	042.559	Carriage Bolt—5/16-18 x 2 in. Long
7	049.551	Wing Nut—5/16-18
8	028.134	Sprocket—50B16 x 1 in. Bore
9	090.203	Shaft Key—1/4 in. Sq. x 1 in. Long
10	029.101	#50 Roller Chain
11	029.201	Connector Link—#50 Roller Chain



www.hytrol.com

HYTROL CONVEYOR COMPANY, INC.
2020 Hytrol Drive
Jonesboro, Arkansas 72401
U.S.A.

Phone: (870) 935-3700

EFFECTIVE FEBRUARY 2007

Printed by Master Printing 2/07